

# AG-RAIN®

## OPERATOR'S MANUAL

### Models

Turbine & Engine Drive

30 x 980    30x1220

33x1120    37x1080

37x1220    40x1250

40x1320    45x1150

### Chassis Sizes

ST4 - ST5 - ST6 - ST7

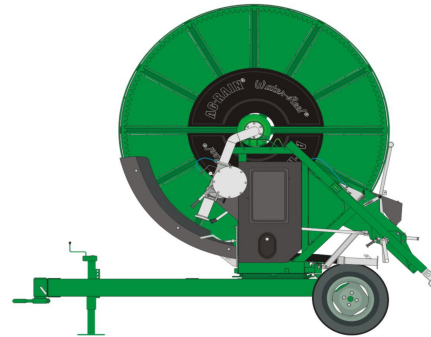

700 South Schrader Avenue

P.O. Box 290

Havana, IL 62644

Phone (309)543-4425

Fax (309)543-4945

[www.Kifco.com](http://www.Kifco.com)

# Introduction

## Thank you for purchasing a Kifco Ag-Rain Water-Reel!

Please read this manual carefully and watch the operator's video to learn how to operate and service your Water-Reel properly before operating your machine for the first time. Failure to do so can result in personal injury and/or property damage.

If you have any problems or are unclear regarding any of the instructions contained herein, contact your local dealer or Kifco prior to operation.

Record the model & serial number of your machine in a safe location. Should you ever require product support assistance from our factory; the process will be much quicker if you have this information available.

This manual is a permanent part of your Water-Reel and should always be available for reference by the operator. This manual should remain with the Water-Reel at all times. Additional copies of this manual are available on our website at [www.kifco.com](http://www.kifco.com).

## Measurements

In this manual all measurements are in U.S. SAE units unless otherwise noted.

## Warranty

A standard Kifco/Ag-Rain warranty is provided. Please see the specific warranty statement in this manual for full details. Neither Kifco/Ag-Rain Dealers nor their representatives are authorized to make exceptions to any warranty policy. Any deviations from the standard warranty require written authorization from Kifco, Inc.

The warranty specifically excludes:

- Alterations or modifications to any part of your new machine not previously approved by Kifco in writing.
- Irrigation tube that is longer, larger in diameter, or made from non-approved materials will void the warranty on the entire machine.
- Damage caused by normal wear, accident, lack of reasonable care and maintenance, neglect or abuse.
- Normal wear items such as belts, gaskets, brake bands, etc. unless these parts are known to be defective.
- Transportation, mailing, service call, diagnostic costs.
- Labor for repairs is also excluded unless unusual circumstances exist and then only if pre-approved.

**Current Parts & Operator's Manuals are always available online at [www.Kifco.com](http://www.Kifco.com).**

# Table of Contents

<b>Safety</b>	<b>1-5</b>
<b>Controls</b>	<b>6</b>
<b>Handling the Polyethylene Tube</b>	<b>7-8</b>
<b>Assembly</b>	<b>9</b>
<b>Lubrication</b>	<b>10</b>
<b>Start-up &amp; Operation</b>	<b>11-30</b>
<b>Start-up</b>	<b>11-16</b>
<b>Depth of Water</b>	<b>17</b>
<b>Speed Compensation</b>	<b>18</b>
<b>Travel Speed Indicator</b>	<b>19-23</b>
<b>Turbine Drive Speed Settings</b>	<b>24</b>
<b>Engine Drive Speed Settings</b>	<b>25</b>
<b>Engine Drive Shut-off System</b>	<b>26</b>
<b>Engine Drive Safety Shut-off</b>	<b>27</b>
<b>PTO Rewind</b>	<b>28</b>
<b>Tongue Jack</b>	<b>29</b>
<b>Hydraulic Control</b>	<b>30</b>
<b>Maintenance &amp; Adjustments</b>	<b>31-39</b>
<b>Compensator</b>	<b>31</b>
<b>Turbine Seal &amp; Bearing Replacement</b>	<b>32-33</b>
<b>Levelwind Timing</b>	<b>34-35</b>
<b>Drive Roller Adjustment</b>	<b>35</b>
<b>Sprinkler Cart &amp; Cart Lift</b>	<b>36</b>
<b>PE Tube Fitting &amp; Mending</b>	<b>37-38</b>
<b>Traveler Speed Indicator (Taky)</b>	<b>39</b>
<b>Winterization &amp; Storage</b>	<b>40</b>
<b>Specifications</b>	<b>41-42</b>
<b>Optional Equipment</b>	<b>43</b>
<b>Warranty</b>	<b>44-45</b>

# Safety

## Owner's Responsibilities

The owner is responsible for the safe operation of this product. The important safeguards and instructions appearing in this manual are not meant to cover all possible conditions and situations that may occur. Common sense and caution should be used at all times by all operators to prevent damage or injury to the operator.

The owner is responsible for:

- Reading and understanding this manual and video. If any instructions remain unclear contact your local dealer or Kifco for further instructions.
- Operating the machine strictly according to prescribed limitations.
- Properly training others who may be permitted to operate the machine.
- Heed the rules of safety, including but not limited to those in these instructions.
- Exercising good judgment relating to safe operation and safe conduct by operators and spectators whether invited or not.
- Always bringing the safety decals and placards on the machine to the attention of operators and spectators.
- **Keeping all shields and guards in place!**

## Read and Heed The Special Messages!

This safety alert symbol is used to indicate messages related to safety. When you see this safety symbol, obey the safety message to avoid personal injury, property damage, or both.

A **“Caution”** message in this manual or on a machine placard means that you could be injured and/or equipment or property may be damaged if you do not follow instructions.

A **“Warning”** message in this manual or on a machine placard means that a hazard exists that could result in severe personal injury or death.

A **“Danger”** message in this manual or on a machine placard means that a hazard exists that will result in severe personal injury or death.



# Safety Decals

All Ag-Rain Water Reels are supplied with a variety of safety decals. These decals must be properly maintained, including replacing any that become illegible or are missing. When replacing safety decals, make sure to install them into the correct location as outlined in this manual.

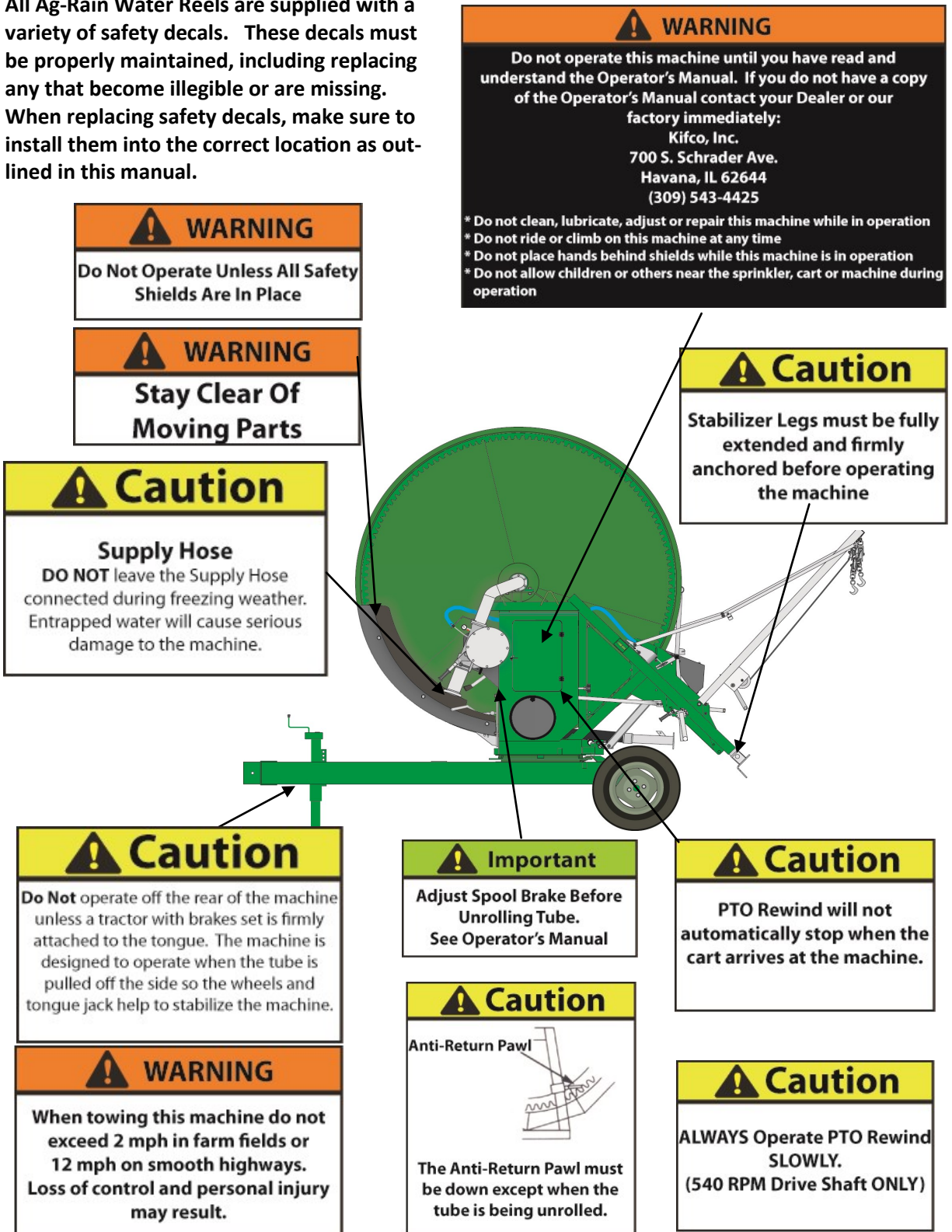

# Safety Decals

## To Disengage Drive (Pull Cart Out)

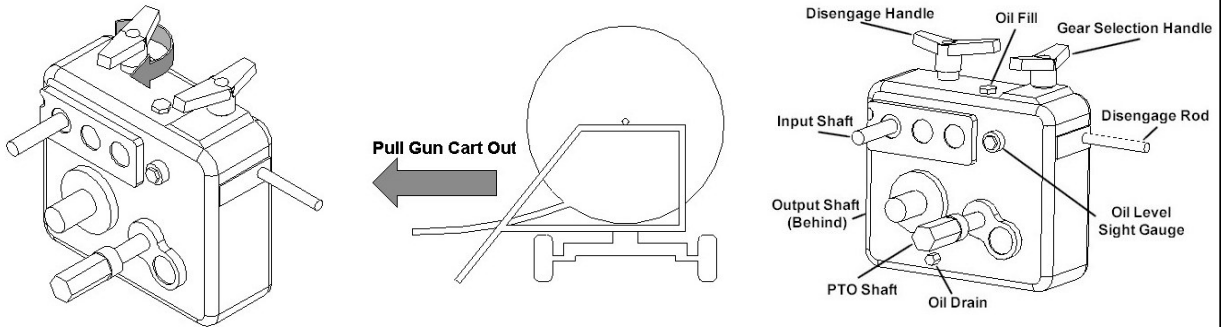

**! WARNING**

The gearbox must be disengaged via the lefthand handle before pulling out the guncart. Failure to disengage the gearbox for cart pull out may damage the gearbox.

The gearbox cannot be shifted into high or low gear until the gearbox disengage rod is pulled sharply away from the gearbox.

The gearbox should never be shifted under heavy load. Shifting the gearbox under load may damage the gearbox.

## To Engage Drive (Run Machine)

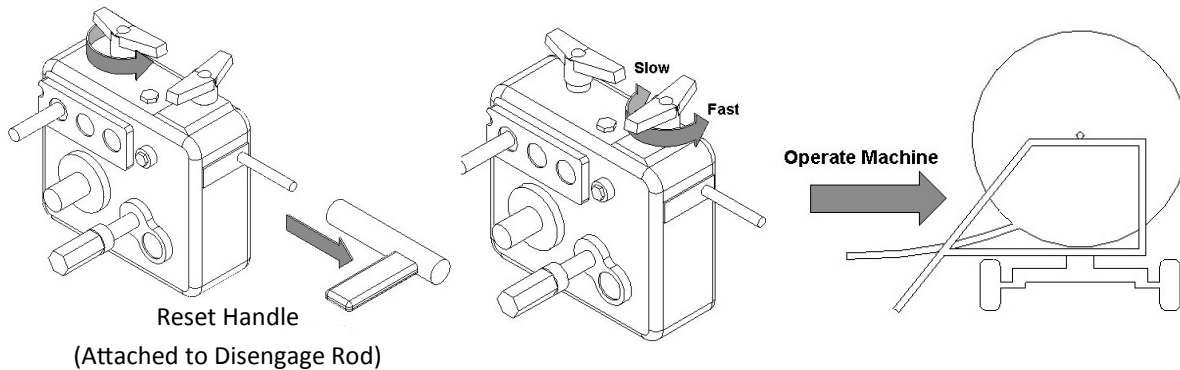

# Safety Precautions

## Learn To Be a Safe Operator

### Read This Manual

- Know the controls on the Water-Reel and how to stop the water supply.
- Do not allow anyone to operate this Water-Reel without proper instruction.

### General Precautions

- **Never attempt to service the Water-Reel while it is operating.**
- **Never attempt to make adjustments to the equipment while it is operating.**
- Perform recommended maintenance at suggested intervals.
- Be certain the stabilizer legs are securely positioned before guncart pullout.

### Protect Children

- Do NOT allow children to operate the Water-Reel.
- Keep children away while operating the Water-Reel.
- Do not allow children to operate the tractor that is positioning the Water-Reel.
- Never allow children to climb or ride on the machine at any time.

### Use Caution Around Pressurized Lines

- For your own protection, always take care when working with or around pressurized equipment. Shut off the pump before working with any components. This includes the pump, supply lines, machine or any related equipment.
- Be sure the pressure is relieved from any supply line before it is disconnected.
- When the automatic sprinkler shut-off is used, pressurized water may be trapped in the system tube.
- Never service the equipment while it is pressurized or in operation.

### Stay Away from Operating Sprinklers

Stay away and keep others away from the sprinkler head during operation. Pressurized water from a sprinkler can inflict serious injury to bystanders.

### Transporting Your Water-Reel

**Caution! Never transport your Water-Reel unless the Anti-Reverse Pawl is in the down position. The Pawl should always be in the down position EXCEPT on guncart pullout!**

Your Water-Reel is not intended for highway towing and should never be towed in excess of 12 MPH.

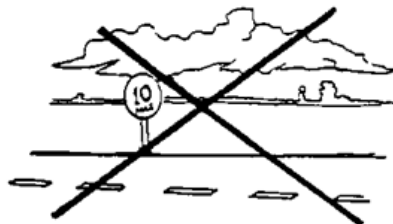

Maximum Towing Speeds
12 MPH on Smooth Surfaces
2 MPH on Rough Surfaces

# Safety Precautions

## Learn To Be a Safe Operator

### Keep Hands and Clothing Away

- Do not reach into any part of the Water-Reel while it is in operation.
- All operators and spectators should keep a safe distance from all moving parts during operation.

### Keep All Guards and Shields in Place

- Never Operate this Machine with Safety Guards Removed!
- Should a shield or guard become damaged or lost, replace it prior to operation.

### Stay Away From Power Lines

Avoid letting water contact power lines. Be careful not to contact power lines with irrigation pipe or mechanical equipment while operating or transporting you Water-Reel.

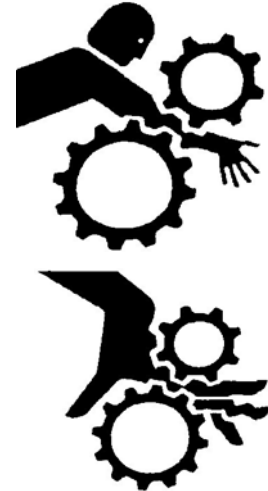



# Machine Controls

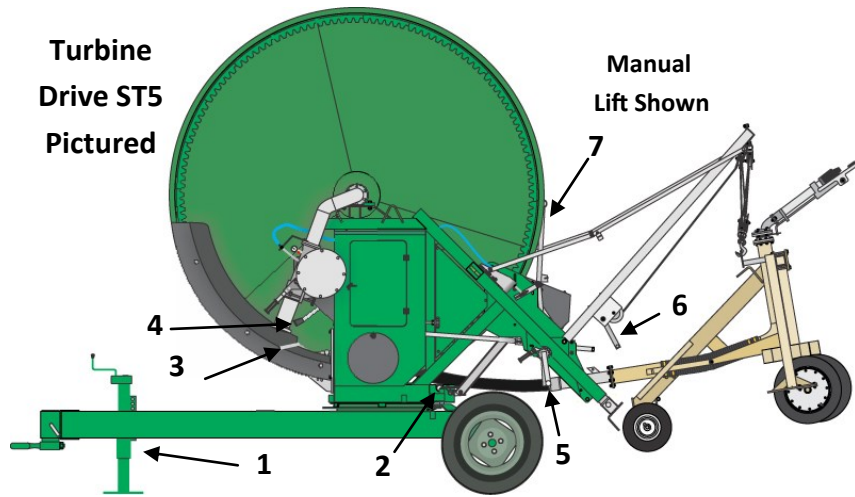

Diag. 1  
Anti-Return Pawl

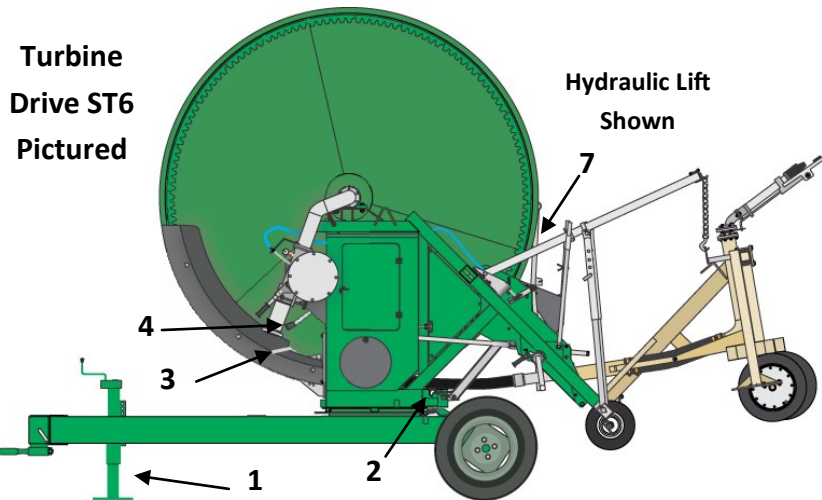
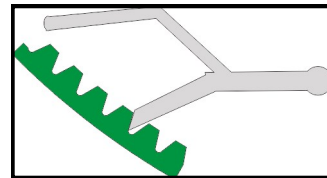

Photo 1  
Turntable Lock Pin



1	Tongue Jack
2	Turntable Lock Pin (See Photo 1)
3	Anti-Return Pawl (See Diagram 1)
4	Three Step Pulley Belt Tensioner
5	Stabilizer Leg Crank Handle (Non-Hydraulic Models Only)
6	Cart Transport Lift Crank Handle
7	Compensator Bar/Shut Off Bar

The controls pictured here are the same for turbine or engine drive systems and for alternate chassis sizes (unless otherwise noted). Controls that are specific to the drive system are show in the “Start-up & Operation” section of this manual.

# Polyethylene Tube

## Precautions for Handling

The polyethylene irrigation tube is a durable product that will operate reliably for many years if handled properly and given a reasonable amount of care.

Medium Density Polyethylene is a semi-rigid product that retains its shape when it is not pressurized but can also be wound on a drum or spool without damage. This characteristic makes it feasible to pump fluid through it while it is rolled up on a reel.

A few simple precautions need to be observed to prevent damaging the tube when operating your Water-Reel.

1. **When starting a new Water-Reel for the first time, you must pull the tube all the way out in order to correctly tighten the new tube on the spool. It is also important to follow the timing instructions on Page 30 of this manual. The Water-Reel must be timed on the first run.**
2. **Never transport the Water-Reel with the anti-return pawl disengaged! The tubing will become loose and tangled.** Do not attempt to operate your Water-Reel if there are any coils of tube that are loose or misplaced. If loose coils of tube are noticed after pulling the tube out, they must be tightened by rotating the spool with the hand crank. If this is not possible, pull all of the tube out before attempting to rewind the tube.
3. Never try to move or relocate the machine if the tube is not fully rewound onto the machine.
4. Never pull the tube off the machine other than by pulling on the sprinkler cart (straight out from the machine).
5. Never run over the tube with any kind of vehicle and avoid pinching or pulling the tube around objects. Never bend the tube sharper than 25 times the inner diameter of the tube.
6. If the tube is frequently pulled out only a portion of its complete length the tube remaining on the drum will become loose. Occasionally it will be necessary to pull all the tube off the drum to tighten the remaining coils.
7. Be careful when operating other equipment near the tube. Make sure the tube doesn't get gouged or punctured.
8. Never leave tube pulled out on ground for more than 12 hours prior to your irrigation run.
9. Avoid using the PTO or engine drive to rewind the tube when it is not pressurized. When the tube is not pressurized during rewind the tube will flatten and the rewind mechanism cannot function properly. **Keep the tube pressurized when rewinding!**
10. The Water-Reel's gearbox is equipped with a brake to prevent coils of tube from becoming loose on the tube spool due to freewheeling of the drum. Loose coils of tube will make the level-wind mechanism appear to be out of time. In this case, the level-wind system will be damaged and a mis-wrap will occur.

# Polyethylene Tube

## Precautions for Handling

If your machine is exhibiting signs of miswrapping, or loose tube see the Maintenance Section, Page 35.

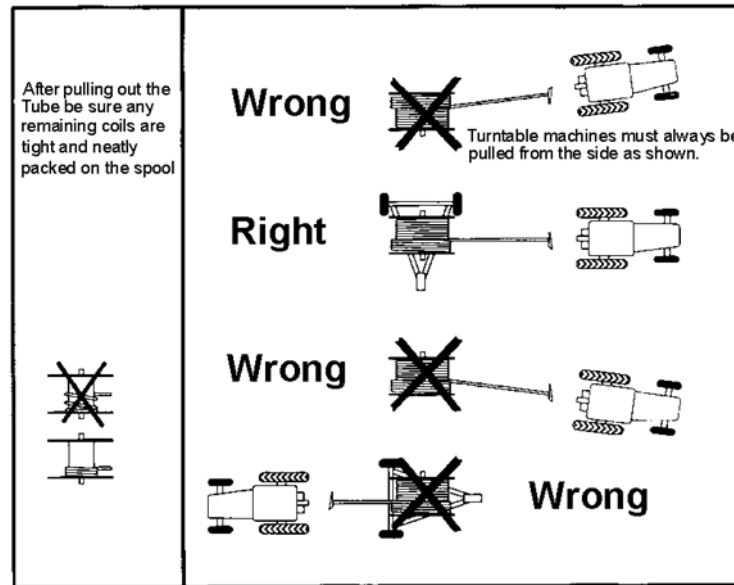

Note: If the tube is pulled out in an arc to follow a contour or to avoid an obstacle, the arc should be very gradual. The arc should not begin until at least 20% of the tube is first pulled out straight from the machine. Under no circumstances should the tube curve more than 90 degrees in its entire length. How well the tube will follow its laid out path back to the machine will depend mostly on the surface of the ground. For example, if there are contours or furrows to follow, the tube may track back very well. If the soil or vegetation is slippery and no rows or furrows exist, the tube may slide sideways across the laid out path and the sprinkler cart will be recoiled back to the machine in a straight line instead of following the intended arc. This will place an excessive side load on the level wind mechanism and may result in equipment failure or tube damage.

# Assembly

Water-Reels are usually shipped with the primary assembly complete. The only items to assemble at the destination are as follows:

1. **Wheels.** Make sure all lug bolts and axle adjustment bolts are tight. They must be rechecked after being towed for any distance greater than one mile.
2. **Sprinkler Cart.** Attach the sprinkler cart to the tube end.
3. **Sprinkler.** Install on the sprinkler cart riser pipe.
4. **Sprinkler Nozzle.** Install the appropriate sprinkler nozzle.
5. **Sprinkler Cart Lift Arm.** Install the sprinkler cart transport lift arm for Water-Reels equipped with the single arm lift.

Final adjustment of the sprinkler cart lift assembly should be made upon completion of the first irrigation run. The lift hooks should be located directly above the sprinkler cart when the sprinkler cart is completely drawn up to the compensation/shut-off bar.

# Lubrication

## Water Resistant Grease (Figures 1-3, 5 & 6)

To keep your Water-Reel operating efficiently, it is important to lubricate it at the designated locations after no more than 100 operating hours or a minimum once per season. Water resistant grease should be utilized.

## Oil (Figure 4)

The gearbox must be kept full of SAE 90 oil. There is an oil sight gauge to assist with assessing this.

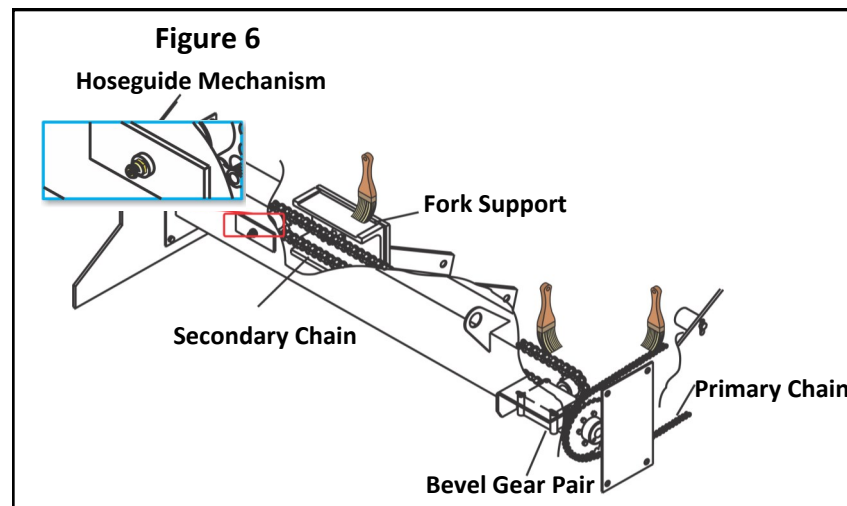
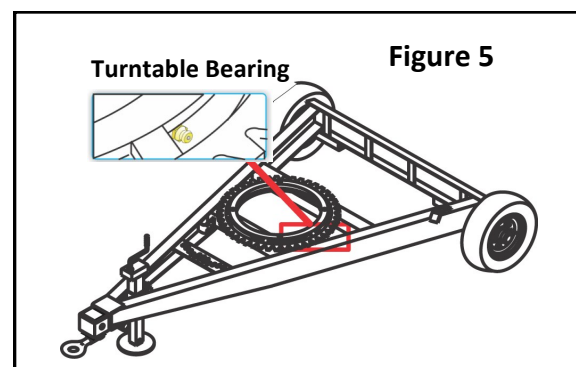
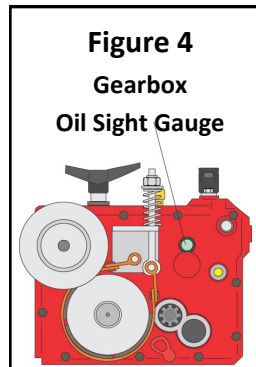
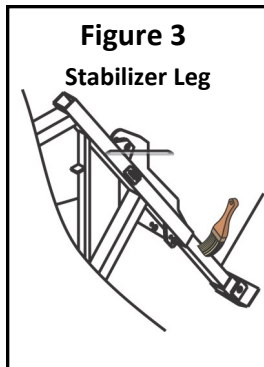
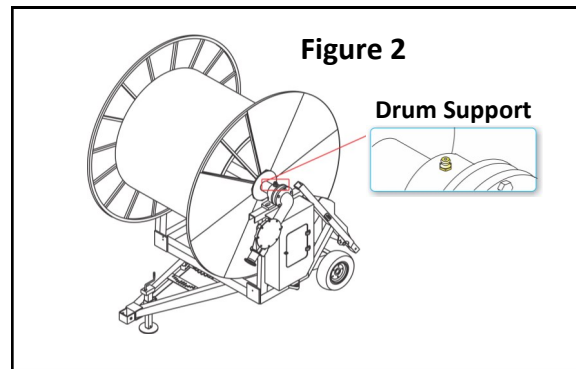
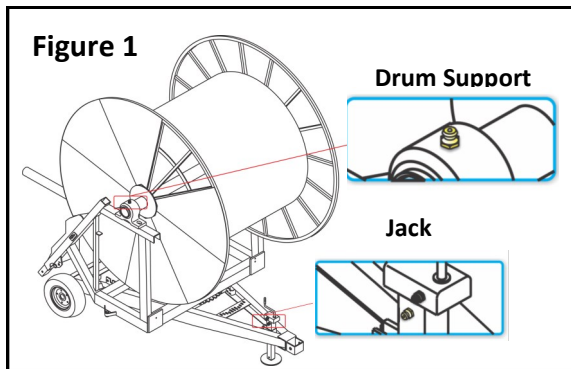

## Figure Summary

1. Drum Support & Jack
2. Drum Support
3. Stabilizer Leg
4. Gearbox (Oil)
5. Turntable Bearing
6. - Primary Chain
- Secondary Chain
- Right Angle Gearbox
- Fork Support

# Start Up & Operation

## Start-Up & Operation Procedure

Successful operation of the Water-Reel irrigation system depends a great deal on the operator's understanding of the proper pullout and start-up procedure. **Do not attempt to operate this Water-Reel until you read and understand the preceding section titled "Precautions when Handling the Polyethylene Tube"!**

### Step-by Step Operation

1. Pull the Water-Reel to the area to be irrigated, parking your Water-Reel and tractor perpendicular to the irrigation lane. Pull the turntable lock pin and rotate the spool so that the sprinkler cart is facing down your irrigation lane and is approximately 90 degrees away from the chassis. Insert turntable lock pin the turntable slot plate and replace the cotter pin to secure it. Be especially careful to have the spool squarely aligned with the sprinkler cart travel path (Diagram Below).

**Pull Into Position**



**Remove Lock Pin**



**Rotate Turntable**



**Replace Lock Pin**



**Warning!** Do not pull the tube off of the back of the machine. The sprinkler cart and tube should always be pulled out at approximately a 90 degree angle to the chassis (diagram below). The stabilizer legs will not hold the load of incoming tube if the chassis wheels are not approximately 90 degrees from the sprinkler cart travel path. See diagram below.

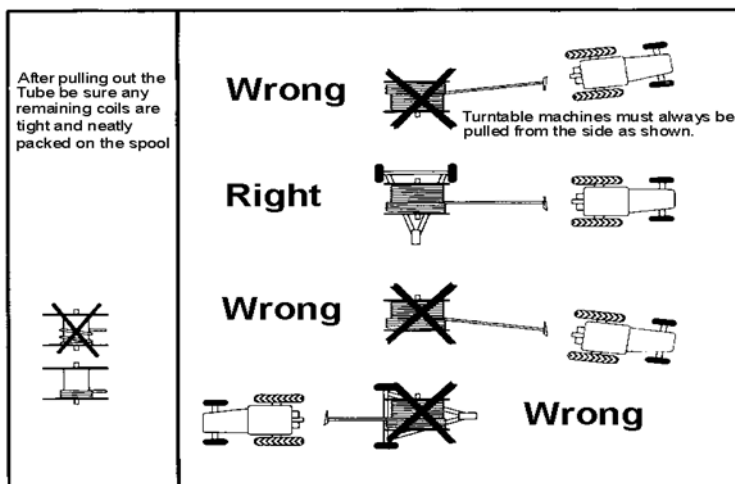

# Start Up & Operation

## Step-by Step Operation Continued

2. Lower the stabilizer legs. Manually crank each leg into the ground or hydraulically extend the stabilizer legs (See Hydraulic Controls Section on Pg. 30) until both stabilizer feet are firmly inserted into the ground. For hydraulic units, your tractor hydraulics will be necessary, this will also lower the sprinkler cart to the ground.

**Warning!** Never operate the Water-Reel with only one stabilizer leg in the ground or without the stabilizer feet firmly inserted in the ground.



3. Lower the adjustable jack (see Tongue Jack instructions Page 25), disconnect tractor hydraulics (if used) and pull tractor around into position to pull sprinkler cart down the irrigation lane.
4. Verify that the chassis of your Ag-Rain Water-Reel is level, if not adjust the jack accordingly. Also verify that both stabilizer legs are securely in the ground.
5. Lower the sprinkler cart from its transport position (this was already completed for hydraulic sprinkler cart lifts). Set the desired sprinkler arc and confirm that the sprinkler is equipped with the proper nozzle. Note: Turbine drive irrigators have a minimum G.P.M. flow requirement. Do not attempt to operate at flows or pressures different from those listed on the "Performance Guide" decal that is installed on the machine.
6. Lift Anti-Return pawl (Diagram below). If the pawl is under pressure, attach the PTO hand wheel to the gearbox PTO shaft and rotate it counter clockwise (Photo below). This will take the pressure off pawl so that it may be lifted. Lock pawl in up position by pushing slide bolt underneath the pawl.

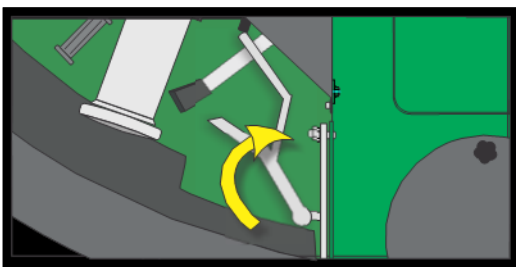

# Start Up & Operation

## Step-by Step Operation Continued

7. Disengage the Gearbox

### Turbine Drive

Disengage the gearbox by turning the left gearbox handle 1/8th of a turn clockwise (as shown below.)

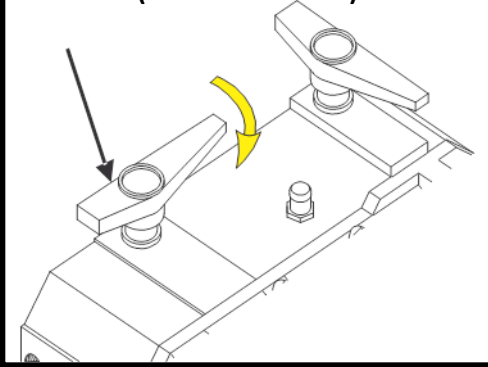

### Engine Drive

Disengage the gearbox by pulling the left gearbox handle (as shown below.)

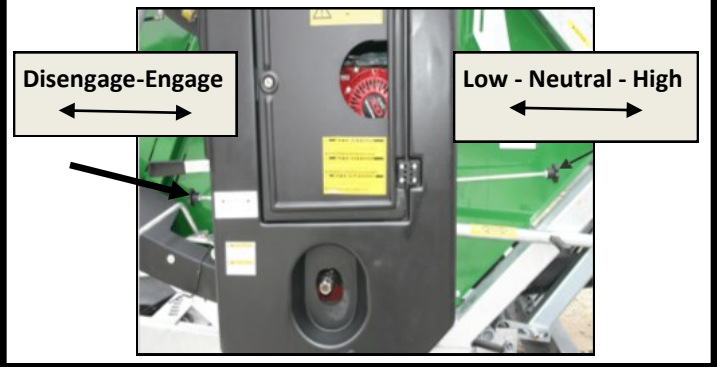

**Warning!** Never pullout the guncart with the gearbox engaged. This will severely damage the gearbox.



8. Pull the sprinkler cart out the desired distance using your tractor; utilizing the chain, clevis and pin provided. Use a gear in your tractor that will not exceed 3 MPH at full throttle. Pull the tube out at a steady rate and do not exceed 3 MPH. Do not start and stop during pull out as this contributes to spool coasting and may result in loosening of the tube. Slow the tractor to 1 MPH or less for fifty feet prior to stopping. **If this is the first run, pull out the full length of the tube. It is important that the first run be a full length run so the tube becomes packed tightly on the reel and Timing can be verified. Refer to page 37.**

**Caution!** If the tube is pulled out in an arc, the first 20% of the tube must be pulled straight away from the machine. Failure to observe this limitation places excessive side load on the level wind mechanism and may result in equipment failure or tube damage. See the section titled "Handling The Polyethylene Tube".





# Start Up & Operation

## Step-by Step Operation Continued

9. Verify that the coils of tube remaining on the drum are both coiled and packed tightly (photo). If they are not use the hand crank and PTO input on the gearbox to tighten them.
10. Adjust sprinkler cart to the desired width. See "Specification Section".
11. Attach supply hose. Verify there are no kinks or twists in the supply hose.
12. Lower the anti reverse pawl prior to engaging the drive system.



### 13. Engage the Gearbox

**Turbine Drive:** Engage the gearbox by turning the left handle counter clockwise 1/8<sup>th</sup> of a turn

**Engine Drive:** Push Left gearbox handle to engage.

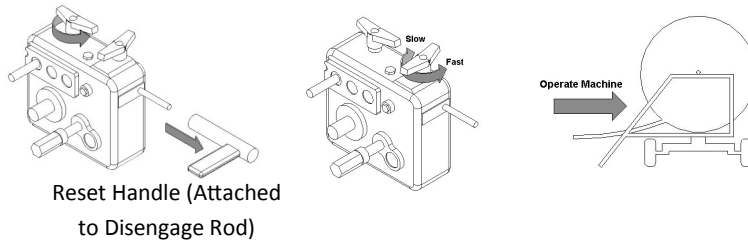

14. Reset gearbox gear selection by firmly pulling the disengage rod away from the gearbox and select fast or slow gear by turning the right had gearbox handle. If the handle does not turn, rotate the gearbox pulley slightly.

# Start Up & Operation

## Step-by Step Operation Continued

15. Make certain the turbine is not engaged and then turn on your pump. If your supply lines have not been used for an extended period of time, flush them prior to attaching your Water-Reel. After all air is purged from the system and the sprinkler is operating smoothly allow water to go through the system for several minutes to carry out any trash or debris that may have been in the mainline pipe. After the system is thoroughly flushed, start the drive system.

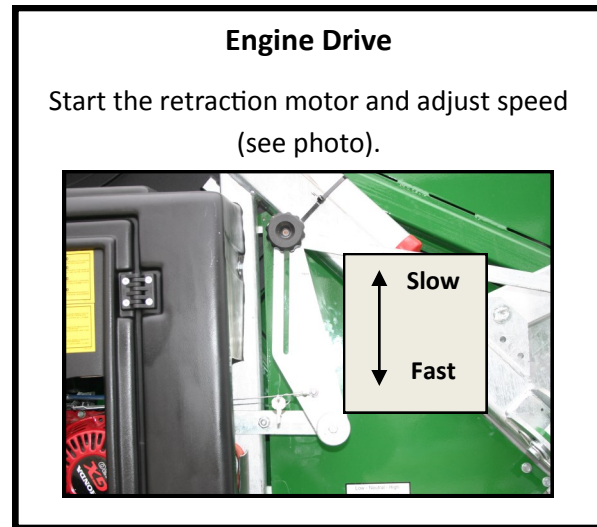
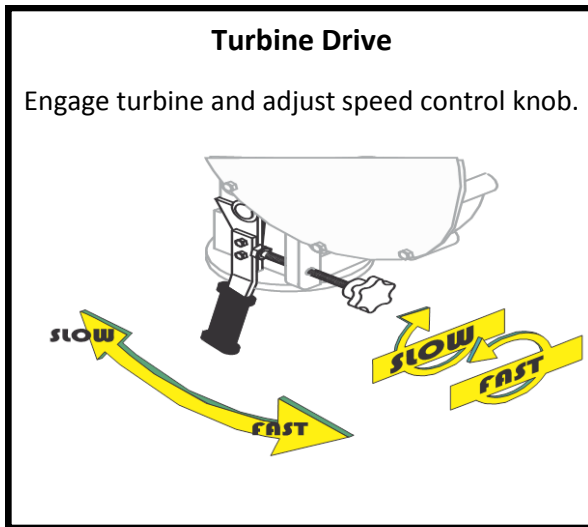

**Warning! Do not pick up or hold Supply Hose as it is being pressurized!**

16. Confirm the sprinkler is operating as expected and in the desired arc. The arc of the sprinkler will affect the precipitation application of the system. Note the "Precip Rate" column on the performance guide located on the Water-Reel. The lowest precipitation rate will occur when the sprinkler is operating a full 360-degree circle.

Note: The upper elbow at main bearing may leak initially at low pressure, but will stop as pressure increases.

Note: Arc settings where the sprinkler never throws water forward of the sprinkler cart could make the sprinkler cart track off line. This is caused by the continuous thrust of the sprinkler that tries to push the tube towards the Water-Reel. It is necessary to have some sprinkler thrust which puts the Tube under tension.

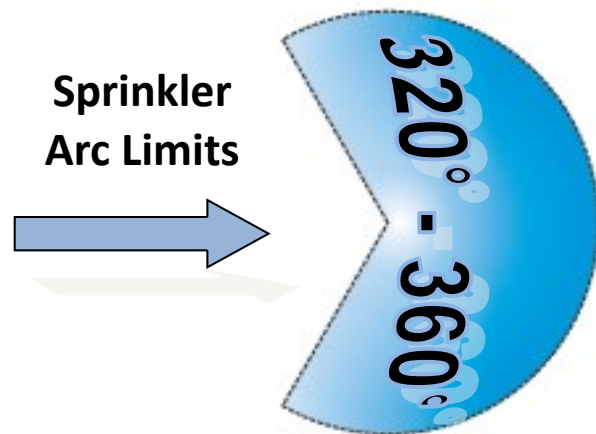

# Start Up & Operation

## Step-by Step Operation Continued

**Warning!** Exercise the compensation/shut-off bar to confirm that the engine and/or gearbox are stopped (See Page 29) when the sprinkler cart reaches the machine. This confirms that the engine shut-off switch and/or turbine gate are properly adjusted and working. Always exercise the compensation/shut-off bar each time before the unit is restarted to confirm proper operation. Do not allow the machine to operate if the shut-off system is not working properly. Damage will result if the machine fails to stop when the irrigation tube is completely rewound.



**Caution!** Do not engage or disengage the gearbox under high loads. Engaging or disengaging the gearbox under high loads may damage the gear train.



17. Observe pressure, travel speed, and sprinkler operation. See the “Specification” section of this manual for performance information and then adjust speed to the desired travel rate.
18. When the sprinkler cart completes the irrigation run and has contacted the compensation/shut-off bar, the retraction of the tube will stop. With the irrigation run completed, stop the pump, lift the sprinkler cart into transport position, retract the stabilizer legs, disconnect the supply hose, and rotate the spool and cradle to the transport position. The Water-Reel is now ready to be moved and set up in a new location. Alternately, the Water-Reel can be rotated 180° to irrigate in the opposite direction while utilizing the same water supply.

# Start Up & Operation

## Depth of Water

The depth of water applied by the Water-Reel is regulated by the speed of the sprinkler moving across the ground and the rate of water being discharged by the sprinkler head. The sprinkler nozzle size and the water pressure at the sprinkler determine the rate of water discharged. The selection of the sprinkler nozzle is made based on the water supply and pump performance.

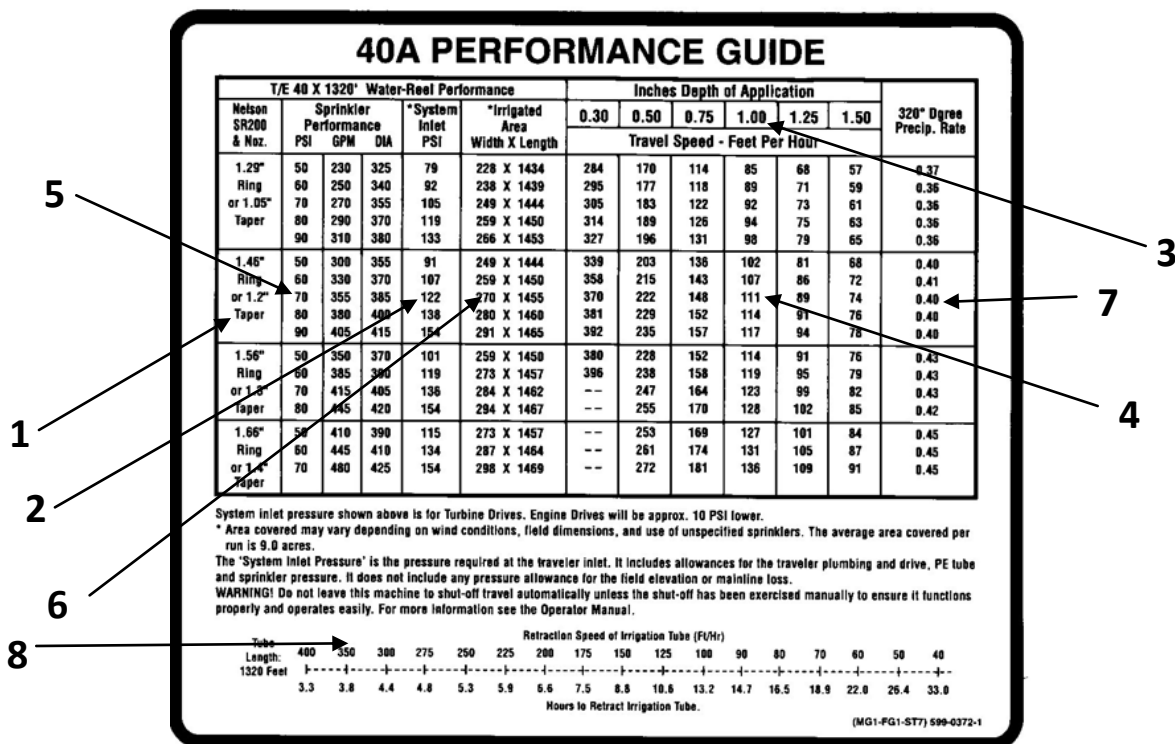

After the desired depth of water has been determined and the proper nozzle has been installed, follow the steps in the following example to set the speed: (Assume: 1.46" ring nozzle in sprinkler, 120 psi inlet pressure on pressure gauge, and a desired depth of water of 1 inch.

1. Find the proper section in the performance Guide for the 1.46" ring nozzle.
2. Locate the 122-psi inlet pressure.
3. Find depth of application 1.00 inch.
4. Set your travel speed as indicated (111 feet per hour in this example).
5. The water pressure on the sprinkler nozzle is 70 psi. The flow in gallons per minute being discharged through the sprinkler is 355 and the wetted diameter is 385 feet.
6. The effective irrigated width is 270 feet and the maximum effective irrigated length is 1455 feet.
7. You can also note the precipitation rate (the rate that water is being applied to the soil) is 0.40 inches per hour. This computation is based on a 320-degree arc of the sprinkler with the arc symmetrical to the direction of travel. See sprinkler arc setting in this section.
8. Hours required for a complete run of about 13.2 can be read from the chart at the bottom of the performance guide entitled "Retraction Speed of Irrigation Tube (Ft/Hr)".

Note: This information is based on standard lengths of tube for the various models. Any tube of a non-standard length or diameter will substantially change the performance. Consult the factory for performance information on non-standard tubes.

# Start Up & Operation

## Speed Compensation

Speed compensation is necessary for uniform application of water. The buildup of tube on the spool gives the spool a larger effective circumference with each layer. With a constant speed of rotation, each layer of tube on the spool makes a significant increase in the rate of sprinkler cart retraction speed during the irrigation run. From the beginning of the irrigation run to the end of the run the typical speed increase of a hard-hose traveler is about 40%. This means that without speed compensation, if you set the travel speed to apply 1 inch of water at the beginning of the run, you will get only 0.6 inches at the end of the run. On the average, the depth is only 0.8 inches. This level of uniformity is unacceptable in most cases.

To better manage the uniformity of application, the Water-Reels are equipped with a speed compensator. The compensator slows the rotation of the spool at approximately the same rate that the tube builds up on the spool so the velocity of the incoming tube stays relatively constant throughout the irrigation cycle.

The compensation system monitors the diameter of the spool by use of a bar that rides on the tube and slows the drive system to offset the increase in the circumference of the spool. The bar is attached mechanically to the turbine motor or to the throttle of an engine drive system.

For Cruise Control equipped machines, the Cruise Control electronically compensates the rotation of the spool. The Cruise Control knows the size of the Water-Reel it is controlling and knows how much tube is on the spool. It then calculates the diameter of the spool and adjusts the rotational speed accordingly. The bar that rides on the tube is not used for speed compensation. It is used for shut-off in the event of a mis-wrap or when the sprinkler cart reaches the machine.

The compensator systems will maintain a reasonably constant sprinkler cart retraction speed throughout the run.

See the "Maintenance & Adjustments" section in this manual for more information about adjusting the turbine or engine compensators.

## Start Up & Operation

### Travel Speed Indicator

The travel speed indicator (Taky) displays the ground speed of the sprinkler cart, amount of hose pulled off machine and layers of tube on spool. The speed is shown in feet per hour for more information refer to taky manual. Cruise Control equipped models do not have a tachometer. The speed is read directly from the Cruise Control screen.

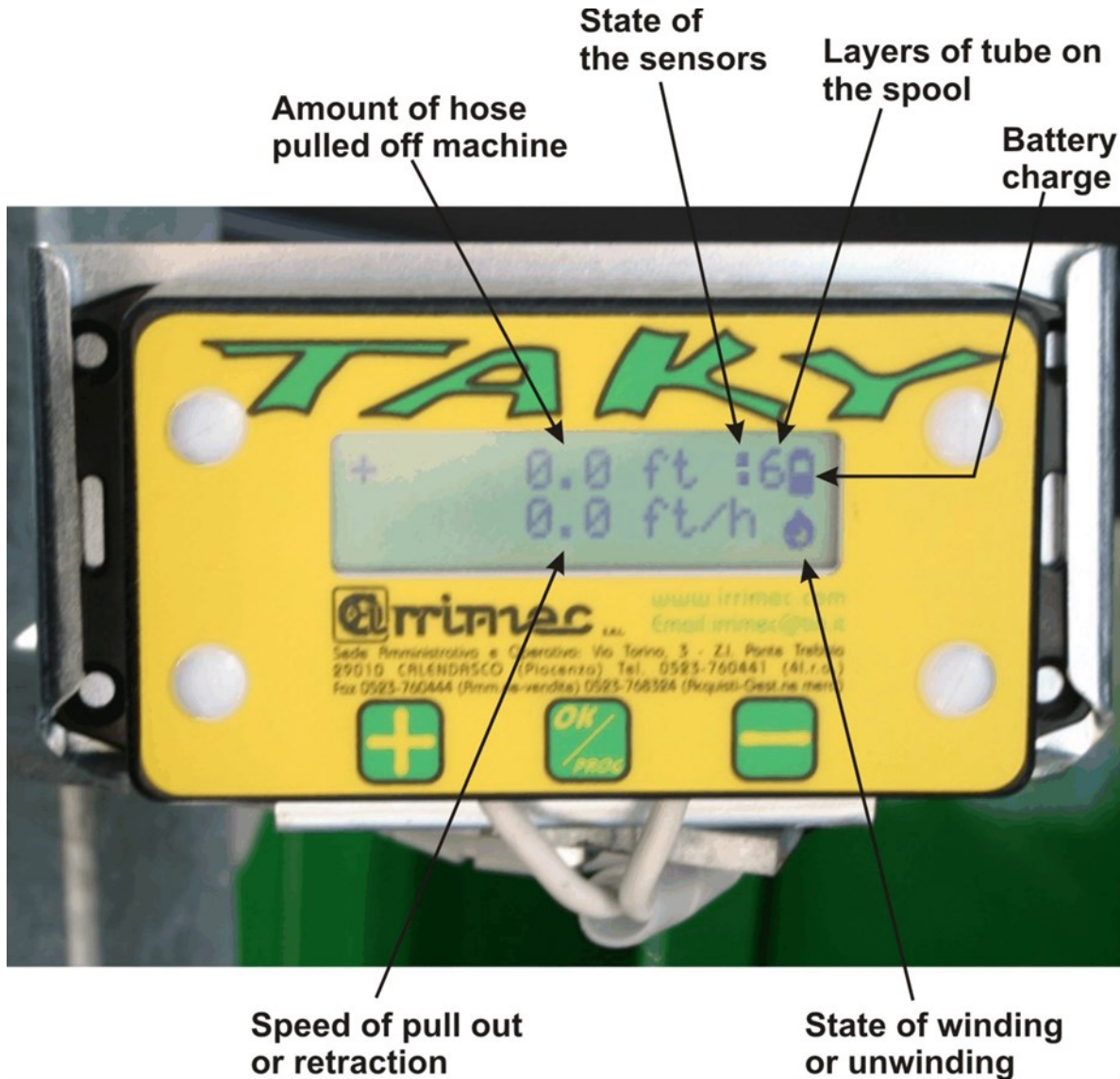



# Taky - Operation

## Traveler Speed Indicator

The travel speed indicator (Taky) displays the ground speed of the sprinkler cart, amount of hose pulled off machine and layers of tube on spool. Please carefully review the following instruction regarding the operation and configuration of the Taky.

### Turn On

- **Press OK** – Once illuminated, **Serial Number and Version** are displayed.
- **The display screen will turn dark after 10 minutes. The Taky will remain in operation even if the screen is dark. Press ok to turn the screen back on.**



### Length and Speed Display

- **The initial screen displays the amount of tube pulled out and the speed of retraction or pullout.**



### Length Adjustment

- **Depress the + or - button for 1 second (when length and speed are displayed)**
- **By holding the + or - button down the advance of the units becomes more rapid.**

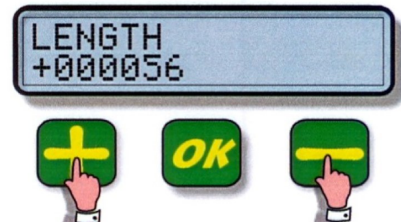

- **To accept the adjusted length value press OK**



**The length is automatically reset upon the transition from pullout to rewind or *visa versa***

# Taky - Operation

## Display

### Length

Length of tube pulled out from 0.00ft to the full amount of tube. This measure can exceed 100% of the tube length do to stretching of the MDPE.

### Speed

Displays the speed of pullout or retraction in Ft/Hr.

### State of Sensors

- ( ■ ■ ) Normal - Both Sensors Displayed
- ( ■ ) Top Sensor - represents pinion sensor is functioning
- ( ) Bottom Sensor represents Gearbox sensor functioning

### Tube Layer

Number of layers of tube remaining on the drum – represents no tube remaining on drum.

**Battery Charge**    ■ FullyCharged    □ Change Battery

**Winding Status**    # Pullout    ⚡ Retraction

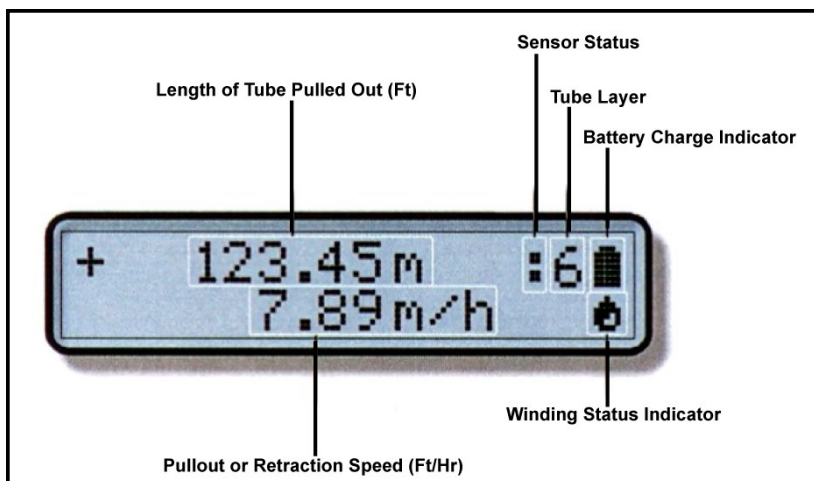

## Configuration

In configuration mode the following items can be adjusted:

<b>Language</b>	<b>Units</b>
<b>Base (ST3-ST8)</b>	<b>PE Tube OD</b>
<b>PE Tube Length</b>	

To enter configuration mode utilize the following steps:

- Press OK in startup Mode (serial number and Version displayed)
- Press + and – simultaneously to enter Configuration Display
- Press + or – to toggle through adjustments





# Taky Operation - Configuration Cont.

## Language

- + or - to select Language
- OK to Confirm

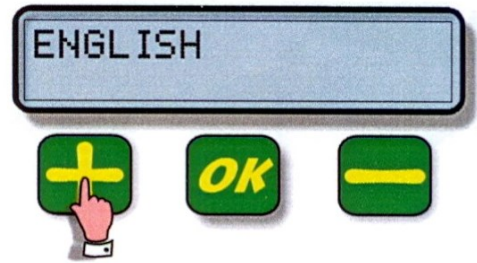

## Units

- + or - to select Units
- OK to Confirm

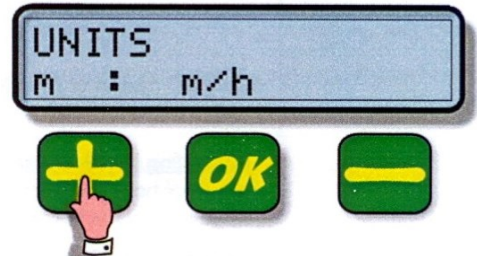

## Base

- + or - to select Base
- Ok to Confirm

(The base eg ST3 can be found on the Serial Tag on your machine – If your base is not displayed on the Taky screen, select MAN and see Manual input instructions)

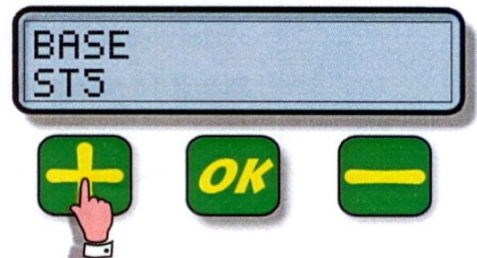

## PE Hose

- + or - to select Hose Diameter (mm)
- Ok to Confirm



## Length

- + or - to select
- OK to Confirm

Hold down the +/- buttons to increase the speed at which the displayed length will change.



## Store Settings

- + or - to select (Yes or No)
- OK to Confirm Choice

Selecting Yes will permanently store all selected settings and these will now be your default settings for the next operation of your Water-Reel.

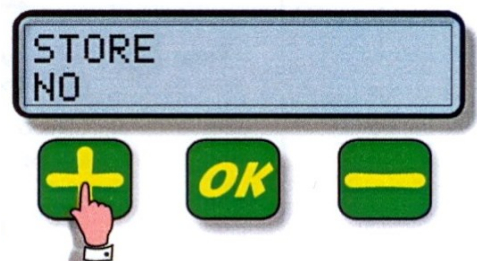

# Taky Operation - Advanced Configuration

## Manual Mode

**Manual Configuration Mode** – If your Base size was not selected and MAN was entered, manually enter the Base specifications

### Drum Diameter

+ or - to select

OK to Confirm

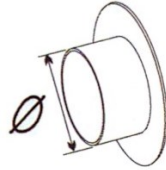

DRUM DIAMETER  
+001500 mm



OK



### Drum Width

+ or - to select

OK to Confirm

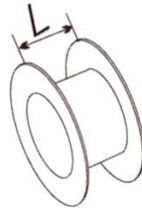

DRUM WIDTH  
+001500 mm



OK



### Number of Rack Teeth

+ or - to select

OK to Confirm

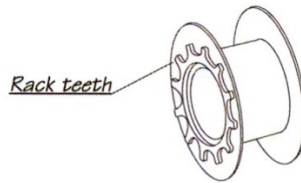

GEAR TEETH N.  
+000150 mm



OK



### Number Pinion Teeth

+ or - to select

OK to Confirm

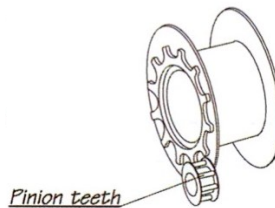

PINION TEETH N.  
+000007



OK



### Reduction Ratio (Between Two Sensors)

+ or - to select

OK to Confirm

REDUCTION RATIO  
+001384



OK



# Start Up & Operation

## Turbine Drive Speed Settings

Select the proper turbine/gearbox v-belt pulley and gearbox range combination. Refer to the speed range chart for correct selection by utilizing the following steps:

1. Select the proper speed range from the "Turbine Drive Speed Range" chart.
2. Select the desired turbine pulley setting based on desired speed of retraction (Ft/Hr).
3. Select the desired gearbox setting with the right gearbox handle (High or Low).
4. Adjust the speed control knob on the turbine (detailed instructions below).

## Turbine Drive Speed Ranges (Approximate)

Turbine Pulley	Two-Speed Gearbox Pulley	Ft/Hr
1		30 - 45
2		45 - 70
3		70 - 95
4		95 - 120
5		120 - 180
6		180 - 300

**Caution!** Do not engage or disengage the gearbox under high loads. Engaging or disengaging the gearbox under high loads may damage the gear train.

**Caution!** Never attempt to change gearbox from High to Low (Right Handle) when the gearbox when the gearbox is under load. Serious damage could occur to the gearbox. See page 21 for instructions on how to remove the load so that gearbox setting changes can be made.



**Caution!** The correct belt position must be used to prevent excessive turbine pressure loss. The life expectancy of the turbine motor bearings and seal will be substantially shortened if the turbine is allowed to run faster than necessary (10psi max). This accomplished as follows:

1. Check inlet pressure prior to engaging turbine
2. Check inlet pressure after engaging turbine.
3. Verify that the pressure loss is less than 10 psi.
4. If the pressure loss is greater than 10 psi, adjust turbine speed control to a pressure loss of 10psi maximum.
5. If additional speed control is required (faster) use the gearbox speeds and pulley settings.
6. Never operate turbine with greater than 10 psi of pressure loss.



With water flowing through the system and the belt position selected, adjust the speed control crank until the desired speed is indicated on the travel speed indicator (see illustration Page 19). Cruise Control equipped models control the speed via the keypad. See the Cruise Control operators manual for complete instructions.

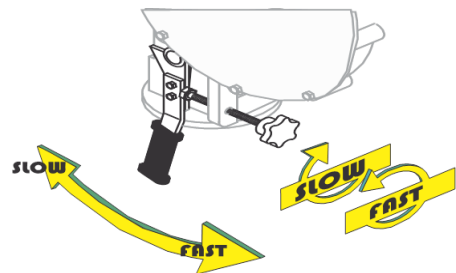

# Start Up & Operation - Engine Drive

Engine Drive Water-Reels are powered by a 4 HP gasoline engine driving a set of two-step pulley reductions and a two-speed gearbox that provides a wide speed range. Most engine powered Water-Reels have a travel speed range from 60 ft/hr to 400 ft/hr. They are speed compensated by the engine throttle.

The engine used on these machines is the Honda GX-120 with a 6 Gallon fuel cell. Operating and service information on the engine is provided by the engine manufacturer and is packed separately with the Water-Reel engine drive machine.

## Setting the Travel Speed

1. Select the proper speed range from the following "Engine Drive Speed Range" chart.
2. Select the desired Jackshaft Pulley setting based on desired speed of retraction (Ft/Hr).
3. Select the desired gearbox setting with the right gearbox handle (High or Low).
4. Loosen the speed control knob and slide the throttle link handle until the desired speed is shown on the travel speed indicator. Retighten the speed control knob. See the illustrations on page 22 for the location of the controls.
5. As the machine progresses, the compensation/shut-off bar will move the throttle linkage and maintain the travel speed as the irrigation tube accumulates on the spool.

Approximate Speed Ranges		Ft/Hr
Engine Jackshaft Pulley	Two-Speed Gear Box Pulley	
	Low	60-100
	Low	90-160
	High	150-250
	High	240-400

**Caution! Do not engage or disengage the gearbox under high loads. Engaging or disengaging the gearbox under high loads may damage the gear train.**

**Caution! Never attempt to change gearbox from High to Low (Right Handle) when the gearbox is under load. Serious damage could occur to the gearbox.**



## Steps for Removing Load for Gearbox Setting Changes

1. Stop machine (Turbine or Engine) and Pump
2. Confirm anti-reverse pawl is down (This pawl should be under load. If it is not, it is now safe to change speed setting. If it is under load, continue to step 3.)
3. Use hand wheel to rotate gearbox PTO counter-clockwise, simultaneously lift the anti-reverse pawl and allow the spool to slowly unwind (one gear tooth only).
4. Repeat step 3 until anti-reverse pawl is no longer under load.
5. It is now safe to change gears.
6. Before restarting your machine, confirm all remaining coils of tube are tight and neatly packed and that the anti-reverse pawl is in the down position.

## Engine Drive Speed Control Linkage

There is seldom any adjustment required to the speed control linkage unless a part has been removed, replaced or damaged. The engine should run at 3600 RPM with the control linkage at its maximum adjustment and with no compensation (tube on first layer).

After starting engine loosen knob and adjust to required speed.

# Start Up & Operation - Engine Drive

## Engine Drive Shut-Off Switch Adjustment

There is seldom any adjustment required to the shutoff mechanism unless a part has been removed, replaced or damaged.

When adjusting the engine shut-off switch, the tube should be on its last layer (Full Spool). Position the bar as if it was on its last layer, the switch ramp should already be in contact with the wobble switch. The wobble switch should just be on the verge of “clicking”. When the switch “clicks”, it grounds the engine ignition & stops.

To ensure that the engine will not run after the irrigation cycle is complete, make sure the wobble switch “clicks” before the gearbox is shifted into neutral. Once the gearbox is in neutral the sprinkler cart will not advance the compensation/shut off bar and the engine grounding switch will be unable to ground the ignition system. The engine will continue to run. As the sprinkler cart comes into the machine, the sequence of events is as follows:

- a. The sprinkler cart will contact the shut-off bar.
- b. The shut-off rod and switch ramp will trip the wobble switch
- c. The engine will shut-off automatically

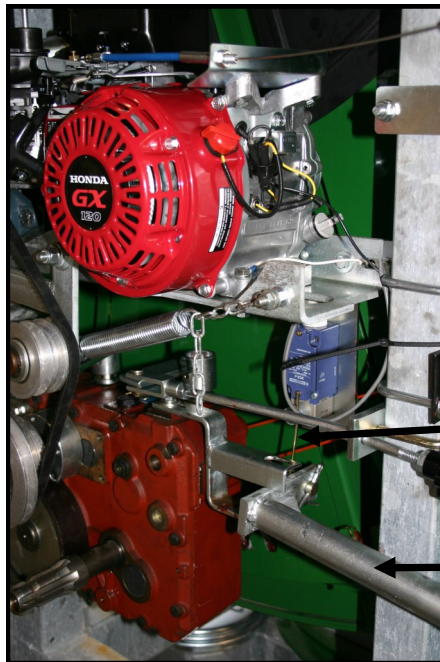

Set switch rod to point where switch is nearly ready to click.

Gearbox Shutoff Lever

**Warning!** Ensure that the gearbox shut off lever will trip the wobble switch before the shut-off bar has reached the level wind frame. If the shut-off bar is allowed to reach the levelwind frame before engine shut down or before the gearbox has been shifted to neutral, machine damage will occur.





# Start Up & Operation - Engine Drive

## Safety Shut Off Adjustment

As previously discussed Engine Drive models are equipped with an engine shutoff switch (primary) and a gearbox shutoff (secondary) which shifts the gearbox into neutral. This is accomplished by the shutoff and hose retention bar. Turbine Drive Models only have the gearbox shutoff. This can be adjusted as follows.

- Adjust the actuator bolt on the lower left of the hose retention bar so it shifts the gearbox into neutral just as the top of the hose retention bar distance between the bar and the last layer of tube is half the diameter of the PE hose (Example if hose diameter is 4.0" setting should be 2.0").
- In normal operation the engine should shut off with the first movement of the hose retention bar however if that system fails the safety system stops the drive, preventing damage to the machine and/or sprinkler cart.

## Functions of the Hose Retention Bar

- A. Stopping the unit when the hose reel tube has completed winding on the drum.
- B. Stops retraction in the event of mis-wrap keeping the hose from getting outside the drum.
- C. Activating the turbine and engine compensation to vary the speed of the drum.

## Stopping the Water Reel

The guncart pushes the stop bar on the hose retention bar and pushes on the stop lever that grounds the engine or puts the gearbox in neutral.

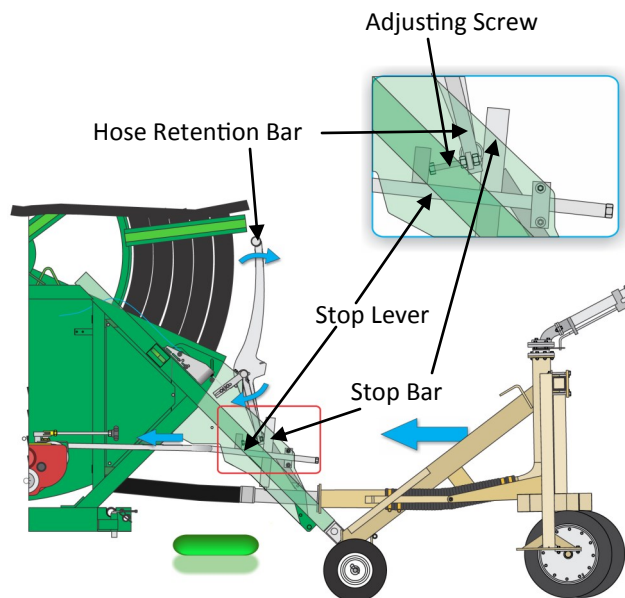

# Start Up & Operation

## PTO Rewind

Your Kifco Ag-Rain Water-Reel is equipped with a PTO spline (540 rpm) for emergency retraction. If it is necessary to retract the tube with the PTO shaft this should always be done with the tube under pressure – water running. This will avoid collapsing the tube by maintaining the operational water pressure during the entire PTO rewind. The tube may collapse or egg if you are using the PTO rewind and do not have the proper water pressure. To operate:

1. Position tractor adjacent to the drive side of Water-Reel
2. Engage gearbox
3. Advance Tractor PTO at a consistent speed
4. Observe that the tube is winding in a tight and consistent manner and is in time with the level-wind fork.
5. STOP the PTO rewind prior to the cart reaching the shutoff bar.
6. Remove PTO shaft
7. Use the hand crank to wind the final distance.

**Warning! When using the PTO rewind, the compensation/shut-off bar will not stop the machine! The operator must manually stop the rewind process. Failure to stop the rewind process while using PTO rewind will result in serious machine damage!**



# Start Up & Operation

## Tongue Jack

Ag-Rain Water-Reel models are equipped standard with either a screw type or manual-hydraulic tongue jack. The tongue jack frame offers a set of 5 adjustment holes to augment the stroke of the screw by 11 inches. The stroke of the screw is 14 inches. See the diagram below. The dimensions apply to both types of jacks.

**Caution! Do not extend the screw-type tongue jack beyond the stroke of the screw. Extending the tongue jack beyond the stroke of the screw may cause damage to the tongue jack.**

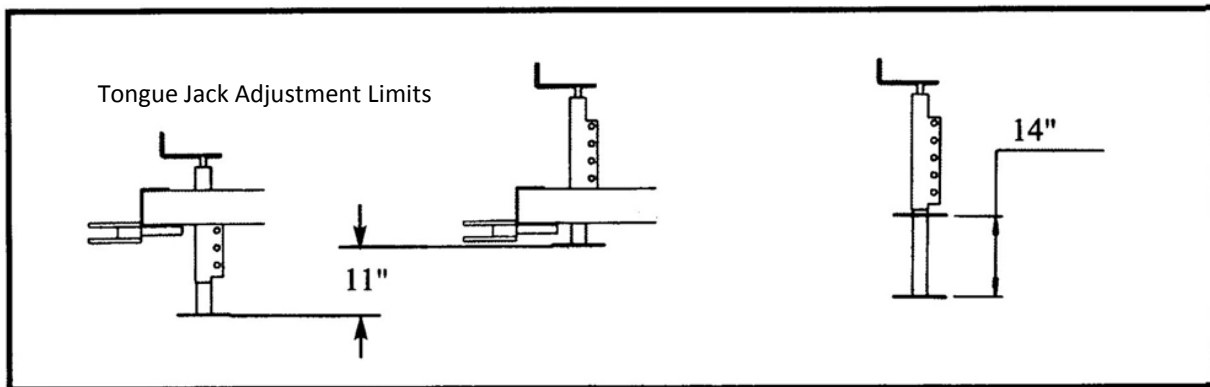

### Hand Crank Jack



### Hand Hydraulic Jack (ST7 Models Only)



**Height Adjustment Pins**



# Hydraulic Controls

Hydraulic controls are standard on the ST6 & ST7 Chassis (models 37x1220, 40x1250, 40,1320 & 45,1150). Hydraulic controls are optional on the ST5 chassis. The stabilizer legs and sprinkler cart lift are linked together mechanically so the hydraulic cylinders move both the stabilizer legs and the sprinkler cart lift at the same time.

The tractor that tows the Water-Reel typically provides hydraulic power for the Water-Reel's hydraulic controls. The control valve on the tractor controls the lifting and lowering of the legs and sprinkler cart.



Hydraulic Sprinkler  
Cart Lift

Sprinkler Cart Lift  
Height Adjustment

Hydraulic Cylinders & Stabilizer Legs

**Caution!** The operator should understand the hydraulic functions before attempting to operate the hydraulic controls. Operate the tractor or hydraulic power source at low engine speeds when using the Water-Reel hydraulics.



# Maintenance & Adjustments

**Danger! All power sources including water pumps must be disconnected and secured before performing any maintenance or adjustments on your water-Reel. Failure to disconnect all power sources before performing maintenance or adjustments may result in machine damage, personal injury, or death.**



Compensator Adjustment:

1. Remove the faceplate of turbine.
2. Remove the spring attached to the turbine compensation arm.
3. Place the compensation bar in the shut off position the bottom of the bar will contact the level-wind frame.
4. Loosen the control wire by loosening the setscrew and the set collar where the control wire connects to the turbine compensation arm.
5. Adjust the compensation spoiler to its fully compensated position it will be pointed directly towards the center of the turbine.
6. Tighten the control wire by tightening the setscrew and set collar attach the spring and exercise the compensation bar to verify the compensation spoiler functions properly with no compensation the compensation spoiler in line with the flow of water and with full compensation the spoiler should be 90 degrees out of line with the flow of water (pointing straight towards center of turbine).
7. Replace the turbine cover and o-ring.

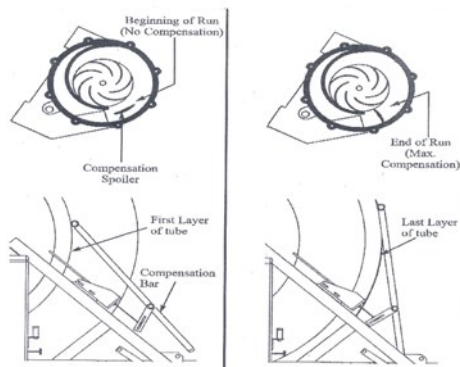

# Maintenance & Adjustments

## ST4 T30/980 Turbine Seal & Bearing Replacement

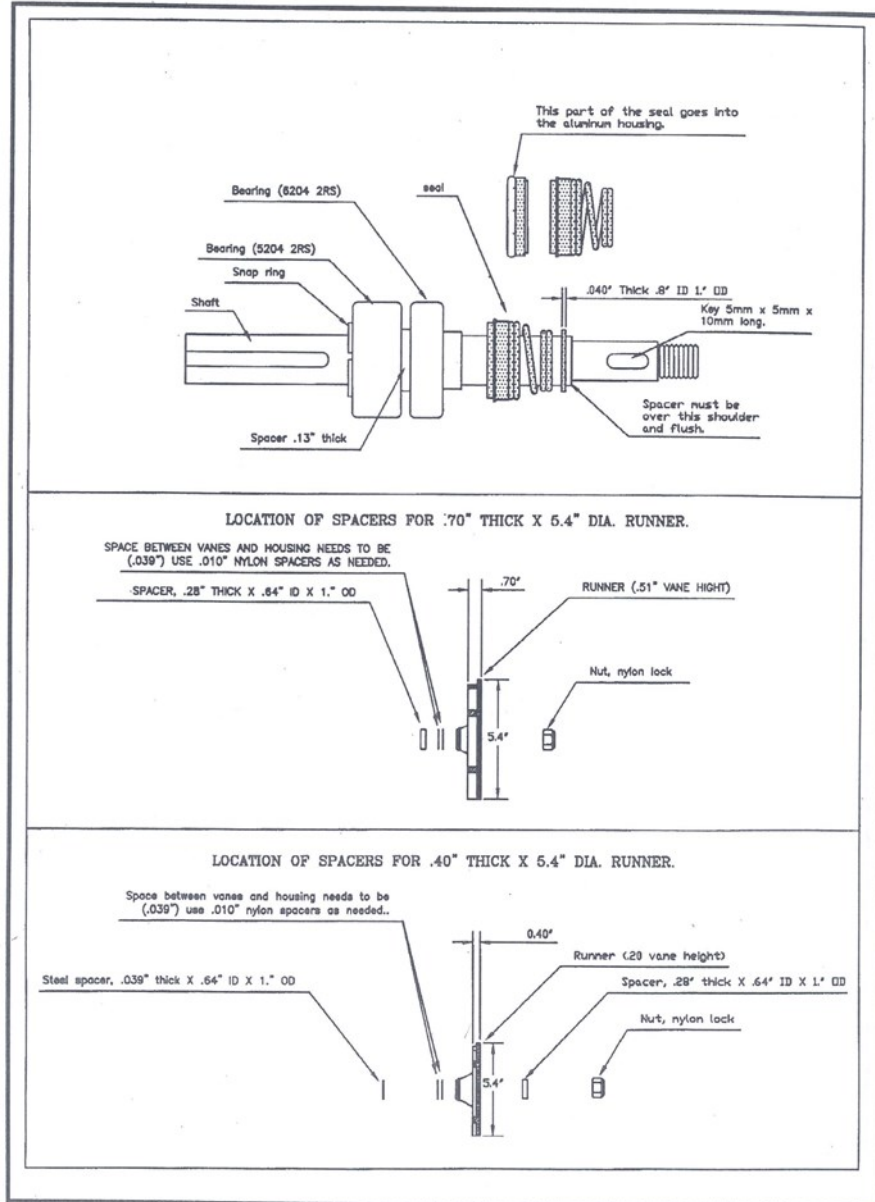

# Maintenance & Adjustments

## ST5, ST6 and ST7

### T30/1200 through T45/1150 Turbine Seal & Bearing Replacement

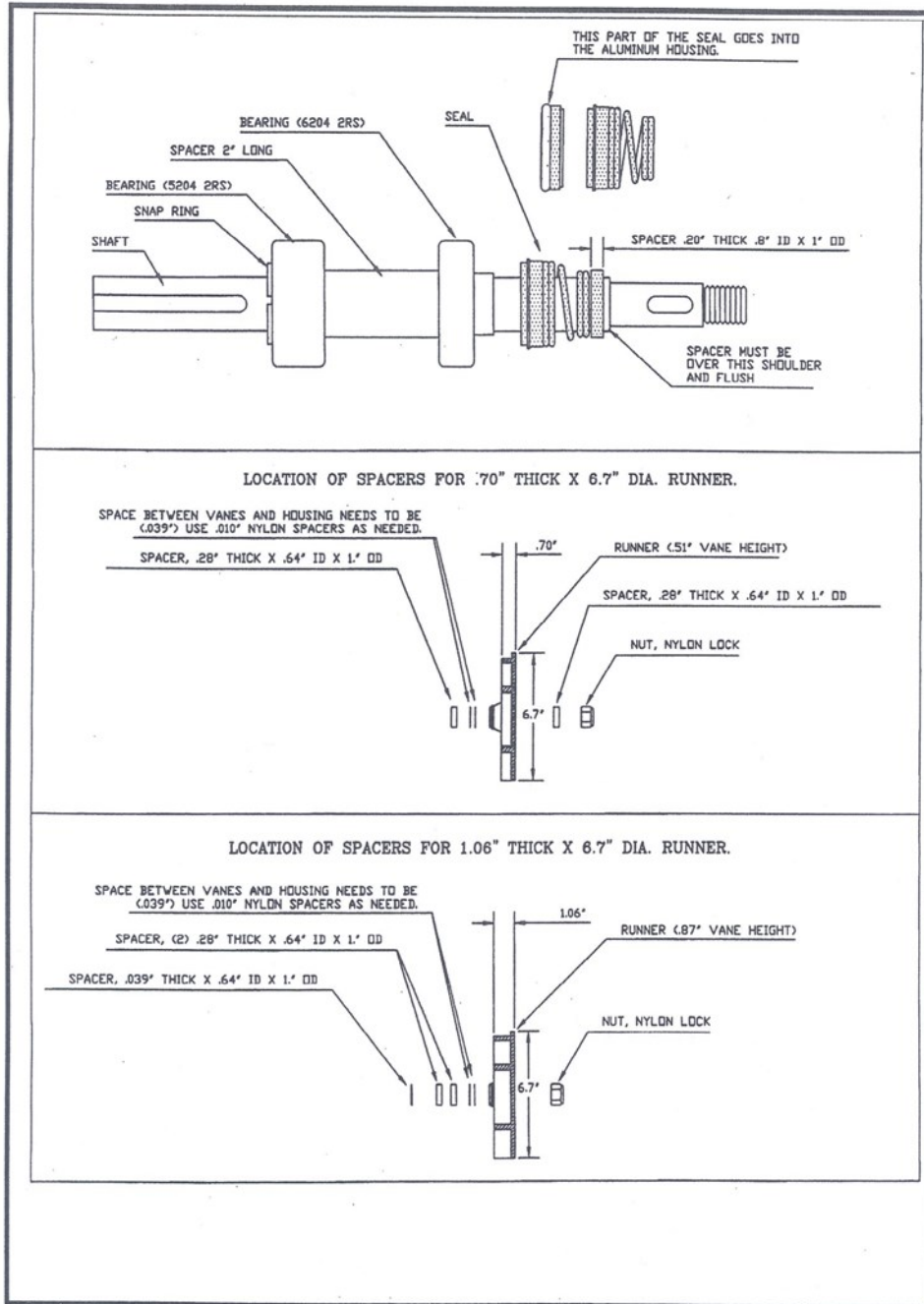

# Maintenance & Adjustments

## Level Wind Timing

Proper timing of the levelwind mechanism is essential for the successful operation of the Water-Reel. Improper levelwind timing will result in mis-wrapped tube. Travel will be interrupted because the auto compensation/shut-off bar will stop the drive system in order to prevent damage to the irrigation tube.

**Warning! Do not continue to operate if the tube is not winding properly! Operation of a machine that is not winding properly may result in machine damage or personal injury.**



**IMPORTANT!** If the machine levelwind appears to be malfunctioning, be positive that the levelwind timing is really at fault before attempting to change the timing. If the tubing is loose on the spool the levelwind system will appear to be out of time. Possible reasons and solutions are:

1. Tube coils were not packed tightly on drum when operation was started. This can be caused by consistently making partial runs (more than 1 layer of tube remaining on drum) or by ignoring loose coils at startup.
2. Tube egg shaping or deformation (bottom layer) due to winding via engine or PTO while the tube is not under pressure. This can be fixed by pulling all the tube out, pressuring the tube up with water and allowing the sun to warm the tube until its shape is regained.

The only way to verify timing is to follow the instruction below:

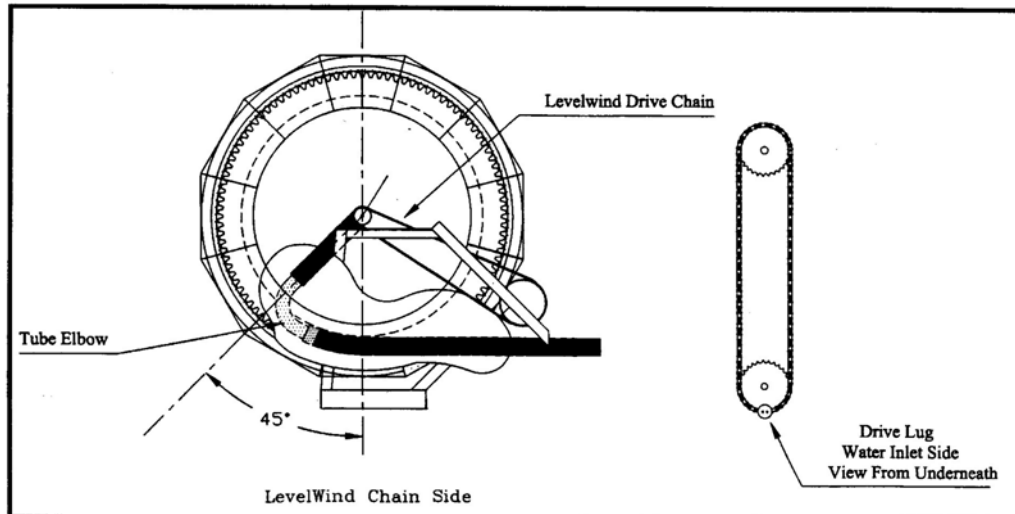

# Maintenance & Adjustments

## Level Wind Timing

### The machine must be timed prior to first run!

1. Pull all the irrigation tube out from the Water-Reel. The elbow to which the tube is fastened must be 45 degrees behind the axle centerline on the bottom of the spool (See levelwind timing diagram). Be especially careful not to pull the tube off the elbow.

**Caution! Never attempt to retime the Water-Reel without first pulling all the tube out. Changing the timing with some of the tube still on the spool may result in damage to the irrigation tube and/or the Water-Reel.**



2. Remove the levelwind fork (4 bolts).
3. Observe the position of the levelwind carrier drive lug master link on the horizontal levelwind chain. (The chain that runs left to right just behind of the compensation bar). The drive lug must be in its most extreme position (half way around the sprocket and on the same side of the Water-Reel as the spool elbow (see video and diagram). If it is not the machine is out of time.
4. To adjust timing, remove the levelwind gearbox shield and cap screws from the levelwind input sprocket. **DO NOT REMOVE THE SPROCKET.** Rotate the hub of the gearbox shaft until the drive lug is positioned as described in step #2. Re-install the cap screws in the new position. Reinstall the levelwind drive chain shield and fork.

## Drive Roller Adjustment

If the drive system has been disassembled, it will be necessary to adjust the mesh of the ring gear teeth to the gearbox drive roller. The ring gear is a large part that will not be perfectly concentric. Tape or fix a felt tip marker to a frame member and rotate the drum with the marker touching the outside face of the main gear. This will mark the point in which the ring gear teeth are closest to the drive roller. Rotate to this point on the ring gear so it is exactly at the drive roller. The clearance is adjusted by moving the clamps that fasten the gearbox mount to the frame of the Water-Reel. Lower the gearbox until the drive roller just contacts the crotch of the teeth of the ring gear, then tighten the gearbox mounting bolts. A scissor jack is ideal for raising & lowering the gearbox. Rotate the spool to be sure the roller to ring gear setting is correct with no interference.

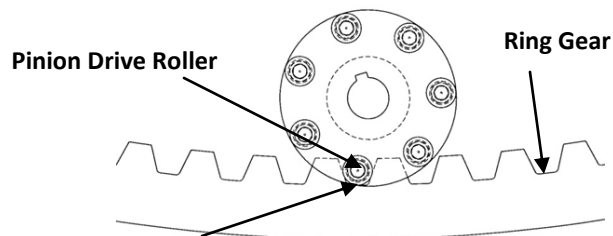

**Point on ring rear that is closest to pinion drive rollers.**

# Maintenance & Adjustments

## Sprinkler Cart Lift

The sprinkler cart lift uses a cable winch or a hydraulically powered frame for transport. The only adjustment required is to locate the lift points (cable winch or chain attachments) from side to side. The lift points should be exactly in line with the sprinkler cart at the end of the run. Because the tube wraps differently when it is pressurized and full of water, it is not possible to locate the lift adjustment points until after the first operation of a new machine. Lift frame height adjustment is made by raising or lowering pins in frame posts.

## Sprinkler Cart

The sprinkler carts used on the Ag-Rain<sup>®</sup> Water-Reels are designed to operate in row crops with the crop height somewhat taller than the underside clearance on standard row-crop tractors that might be used to pull the tube out.

For best performance it is desirable to keep the sprinkler height as low as possible. There are two important reasons. First, the stability of the cart is less affected by the thrust of the sprinkler. Second, wind has considerably less effect on the performance of the sprinkler. See the section titled "Specifications."

**Warning! Keep all persons away from operating sprinklers! Contact an operating sprinkler may result in personal injury or death.**



The sprinkler carts have adjustable width rear axles. The rear axle should be adjusted to the maximum width compatible with the crop being irrigated for best stability. For adverse conditions such as hillsides, extra high flow, or high pressure, ballast may be required to prevent the cart from tipping over. Additional ballast can be obtained by filling the rear tires with fluid.

The sprinkler cart has been adjusted to track straight from the factory. Tracking can be adjusted by adjusting the angle of the front wheel is via slotted and oversized holes. To assure straight tracking, take the cart to a concrete floor and push 50 feet down a chalk line to confirm tracking in a straight direction. Tracking be corrected by trial and error in the field. If the cart does not track in a straight direction the tube end will appear as though it has a bend in it. This is not the case. Cutting the end off the tube will not solve the tracking problem.

Study the chart regarding sprinkler cart specifications in the section titled "Specifications" before adding riser pipe extensions or adjusting the wheel track width.

The chart shows the height of the water stream at 5 foot and 10 foot distances from the riser pipe. Be sure to consider the trajectory of the sprinkler when determining the sprinkler height and keep the sprinkler as low as possible.

# Maintenance & Adjustments

## Installing Polyethylene Tube Fittings

**Danger! Installing fittings or repairing polyethylene tube used on your Water-Reel is hazardous! The tube has a shape memory from being coiled on a reel and will coil back with great force as the tube is released from one end or severed. This condition poses a serious hazard to personnel and/or property. The tube must be properly restrained anytime the tube or the tube fittings are being repaired or replaced.**



The fittings used on the ends of the polyethylene tube are made to screw into the tube much the same way as a field repair of a hydraulic hose. A threaded insert screws into the inside of the tube while an outer sleeve keeps the tube from enlarging as the insert is installed. This provides a watertight seal and a secure grip on the tube for dragging.

The following steps should be followed when installing fittings:

1. Secure the end of the tube by fastening it to a tractor or other heavy object. Cut the tube. Make sure the cut on the end of the tube is square.
2. Chamfer the inside of the tube by using a sharp knife, wood rasp or a reamer. Reamers are available for tubes 2.5 inch I.D. through 4.5 inch I.D. Your dealer may have a reamer that you may rent or buy. The tube should be chamfered evenly until approximately  $\frac{1}{4}$  of the threaded portion of the fitting can be freely pushed into the tube by hand without turning.
3. Before putting the sleeve on the outside of the tube, screw the threaded portion of the fitting into the tube. Take care to keep the fitting and the tube aligned while threading. This process cuts a partial thread in the tube which makes it easier to keep the fitting straight during the final installation. Remove the fitting.
4. Now place the sleeve on the tube and push it on until it is flush with the cut end of the tube.
5. Apply lubricant to the fitting and to the inside of the tube. The best lubricant is liquid dishwasher soap. Now screw the fitting in until all the threads are in the tube. Again, take care to keep the fitting straight.

Reach inside the coupling and remove any shreds of polyethylene created as a result of cutting the thread in the tube. These may foul the sprinkler.

Tools used during installation depend on which fitting is being installed. To install a flange-style fitting, use bar 5 or 6 feet long placed between two bolts inserted through the holes in the flange. For the spool elbow, use a pipe and/or a large pipe wrench. For fittings with drive lugs inside the fitting, a special installation tool is required. This tool is not provided with the fittings.

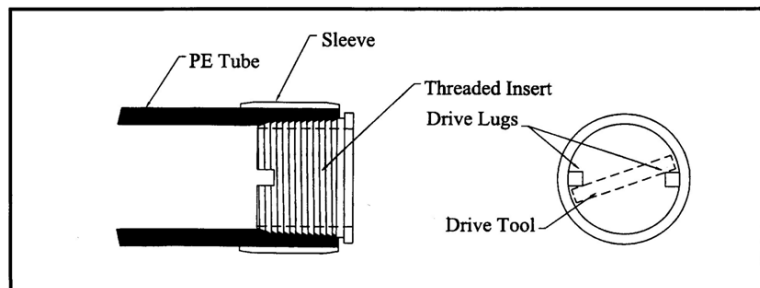



# Maintenance & Adjustments

## Installing Polyethylene Tube Fittings Continued

The following diagram shows a typical driver for these fittings. The blade of the driver is made from 3/8" x 4" plate. The width of the blade is the same or slightly less than the diameter of the fitting. Weld the blade to a heavy steel bar or 1" schedule 80 water pipe approximately 48" long.

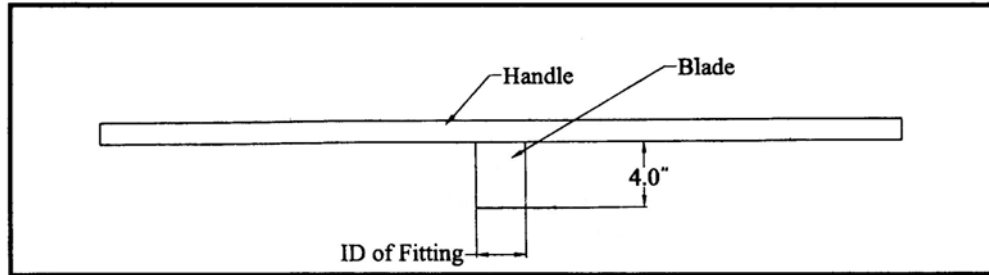

Typical Driver Tool

## Screw-in Tube Menders

Screw-in menders must be installed with the Driver Tool. The menders are joined with a threaded collar much the same as a typical pipe union. See following diagram.

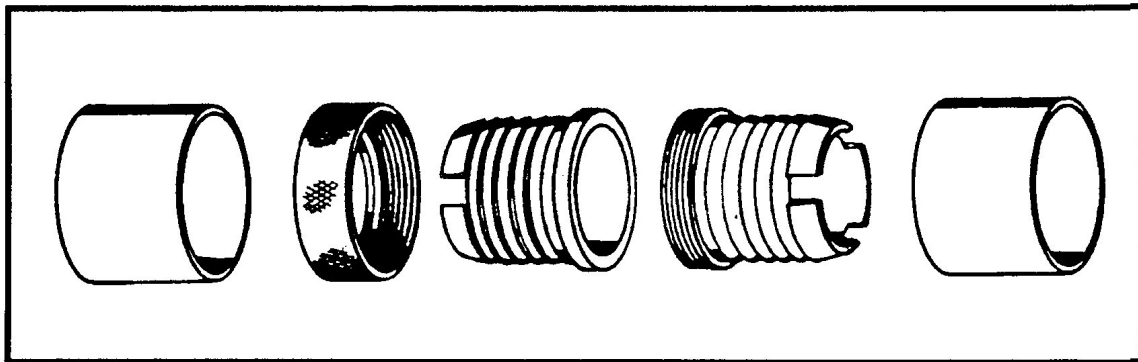

Screw-in Mender

# Taky Maintenance

## Battery Replacement

**Only use 1.5v alkaline batteries (AA). Rechargeable batteries are not compatible with this system.**

- **Remove the 4 screws from the cover.**
- **Replace the batteries.**
- **Press the reset button to restart the circuit.**

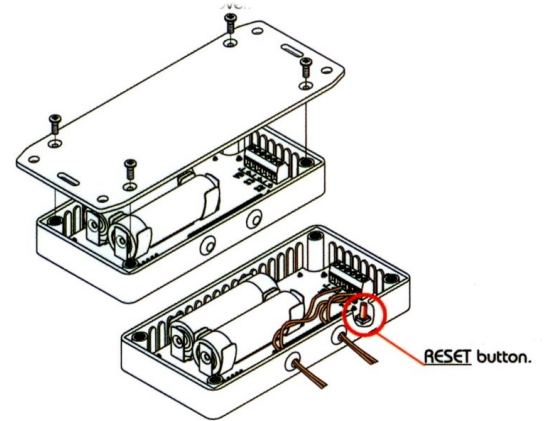

**When replacing the battery the Taky will not have to be completely reprogrammed; however, you will need to reset the length.**

## Electrical Connections

- **Terminals VB+ and VB- are not used (Figure 1)**
- **Terminals S1+ and S1- must be connected to the pinion sensor (Polarity Same) (Figure 2)**
- **Terminals S2+ and S2- must be connected to gearbox tach shaft sensor (Polarity Same)**

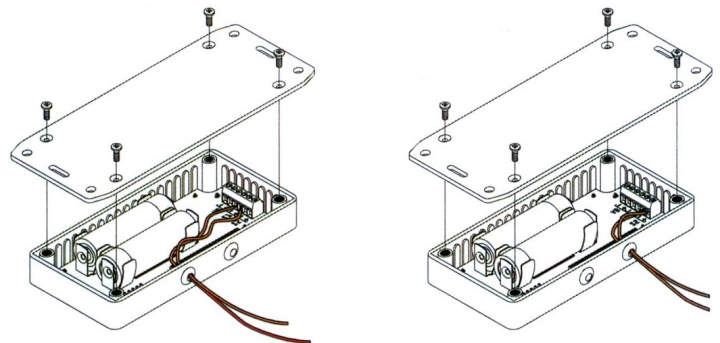

# Maintenance & Adjustments

## Winterizing and Storage

### Winterizing

Be certain that the drain valve or ball plug on the sprinkler cart body is open and the sprinkler cart is lowered from the sprinkler cart lift so that all water is drained from the sprinkler cart. Disconnect the sprinkler cart from the end of the irrigation tube to be sure all of the water is out.

Be certain the water inlet to the Water-Reel is open and the water supply hose removed. Pull 1 or 2 coils of tube off the spool to expel some of the water from the spool axle and sprinkler cart fittings. Rewind the coils of tube by using the hand crank.

Freezing will not damage the polyethylene tube used on your Water-Reel! Pulling the tube all the way out to drain the water then rewinding with the PTO is not recommended! This process is not effective and exposes the system to damage. Please read the section titled "Handling the Polyethylene Tube."

**Caution! Even though the polyethylene tube does not need to be drained, all the metal parts must be drained before the Machine is subjected to freezing temperatures. Failure to drain all the metal parts may result in machine damage.**



### Storage

1. Refer to the section titled "Lubrication" and lubricate all points to prevent rust and corrosion from forming.
2. Store the Water-Reel away from the direct rays of the sun.
3. Make sure all openings such as the water inlet are plugged so rodents and insects cannot bring foreign material into the Water-Reel.
4. When taking the Water-Reel out of storage, be sure there are no rodent or insect nests inside the tube end of the Water-Reel.
5. For engine driven machines, service the engine in preparation for the next season.

# Water-Reel - Specifications

## Dimensions & Weight

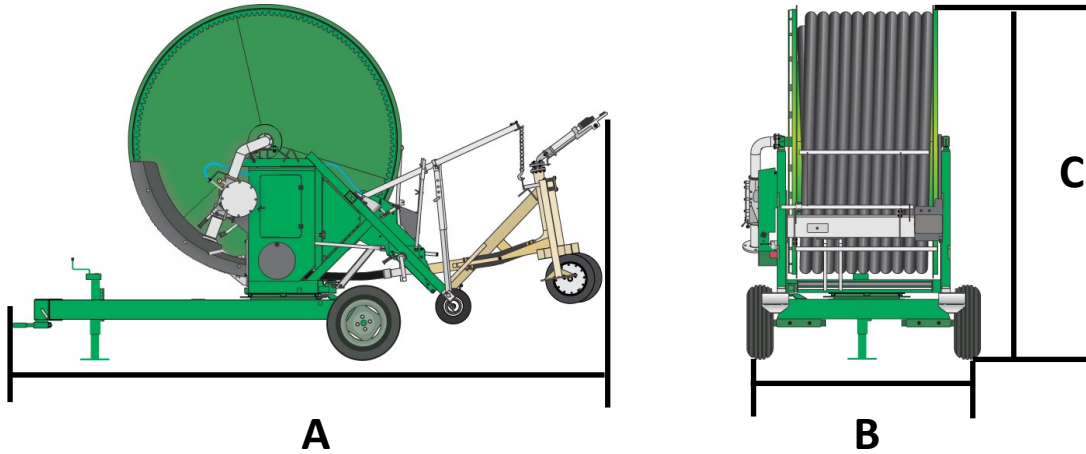

**Ag-Rain Water-Reel Dimensions w/ Guncart (Feet)**

Label	ST4	ST5	ST6	ST7
<b>A</b>	<b>11.58</b>	<b>19.59</b>	<b>20.31</b>	<b>21.30</b>
<b>B*</b>	<b>7.25</b>	<b>7.25</b>	<b>7.88</b>	<b>8.79</b>
<b>B**</b>	<b>8.33</b>	<b>8.25</b>	<b>9.59</b>	<b>10.10</b>
<b>C</b>	<b>9.50</b>	<b>10.83</b>	<b>10.66</b>	<b>12.04</b>

\* Represents width at factory setting.

\*\* Represents width at maximum.

**Ag-Rain Water-Reel Weights (lbs)**

Description	30/980	30/1200	33/1120	37/1080	37/1220	40/1250	40/1320	45/1150
<b>Dry Weight</b>	<b>3831</b>	<b>3945</b>	<b>5365</b>	<b>6569</b>	<b>6805</b>	<b>8632</b>	<b>8765</b>	<b>9300</b>
<b>Weight w/ Water</b>	<b>6837</b>	<b>6974</b>	<b>11237</b>	<b>11598</b>	<b>14549</b>	<b>15434</b>	<b>18750</b>	<b>17180</b>
<b>Hitch Weight (Dry)</b>	<b>441</b>	<b>515</b>	<b>864</b>	<b>1126</b>	<b>1166</b>	<b>1500</b>	<b>1629</b>	<b>1570</b>
<b>Hitch Weight (Water)</b>	<b>1130</b>	<b>1470</b>	<b>2517</b>	<b>2605</b>	<b>3268</b>	<b>3772</b>	<b>4582</b>	<b>4235</b>

Hitch weights assume front axles are off the ground. Operational tongue weight will be less.

**Ag-Rain Water-Reel Retraction Speed Range (Feet per Hour)**

<b>Turbine Drive</b>	<b>30 - 300</b>
<b>Engine Drive</b>	<b>60 - 400</b>

## Sprinkler Cart - Specifications

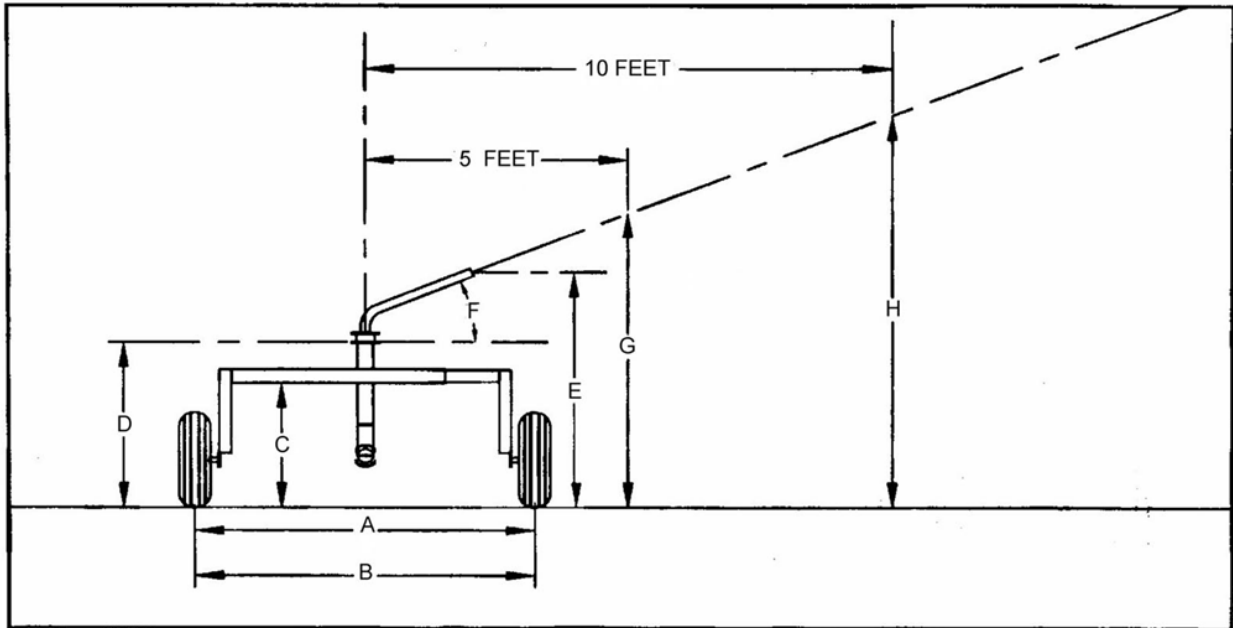

Dim.	Description	40/1320 45/1150	37/1220 40/1250	30/1200 33/1120 37/1080	30/980
(A)	Wheel Track Minimum	56"	56"	56"	56"
(B)	Wheel Track Maximum	85"	85"	85"	85"
(C)	Crop Clearance	47"	47"	47"	46"
(D)	Sprinkler Base Height	56"	56"	56"	56"
(E)	Nozzle Height	83"	77"	77"	77"
(F)	Trajectory (Degrees)	27	24	24	24
(G)	Stream Height. 5 Feet.	113"	101"	101"	101"
(H)	Stream Height. 10 Feet.	160"	144"	144"	144"

The above information is based on the sprinklers supplied as standard by Kifco, Inc. If a different sprinkler is being used this information may not be correct. The Stream Heights are to the centerline of the system. **All dimensions are approximate!**

## Optional Equipment

- High Pressure Shut-Off System (Clean Water Only). This system is designed to send high backpressure to the pump when the sprinkler cart reaches the Water-Reel compensation/shut-off bar. The pump must be equipped with a high-pressure shut-off switch. The valve contains a slow-closing diaphragm that gradually increases the pressure on the pump. This device requires a supply pump with a performance curve that will provide the appropriate pressure rise to activate the high-pressure shut-off pump switch (not included with this kit). Also the pipeline to the Water-Reel must have a pressure rating high enough to tolerate the total pump head. Notice: Kifco, Inc. accepts no responsibility for any consequential damage resulting from improper installation or operation of this device.
- Cruise Control. Kifco's electronic speed control offers state-of-the-art speed management as well as delayed start. Information such as time to completion and length of tube remaining is also displayed.
- Riser Pipe Extensions. Extensions for elevating the sprinkler on the sprinkler cart are available. They are available in one and two foot lengths.
- Filter Cone. Filter cones should be used on all turbine driven Water-Reels used for slurry and irrigation operations where foreign objects such as rocks are known to be present. The stainless steel cone inserts into the supply hose at the inlet of the machine. Available in three or four inch diameters (must match inlet size).
- Hydraulic Stabilizer Legs/Sprinkler Cart Lift. Hydraulic stabilizer leg and sprinkler cart lifts are available on ST5 Models.
- Hydraulic Turntable/Tongue Jack. Hydraulic turntable and jack are available as an option for ST4, 5, 6&7.
- Crossover Pipes. If your application must feed the water from the opposite side of the machine, Kifco sells crossover pipes for all the new ST-Series models.
- Booster Pump. The 30A980, 30a1200 and 33A1120 have 18hp and 23hp booster pumps available if your application demands higher pressure at the sprinkler. See your dealer for information.
- Engine Drives. All the new ST-Series have engine drive kits available. These kits can be factory installed.
- Sprinkler Options. Kifco offers several choices in large sprinklers for their Water-Reels.



## Warranty

KIFCO products are warranted to the original user for a period of one year from the date of his purchase invoice, that the equipment will be free from defects in material and workmanship subject to the following conditions:

Satisfaction of this warranty will be limited to the replacement or repair or modification of the equipment involved at the manufacturer's option. The manufacturer's obligation under this warranty shall be limited to a credit to the dealer or customer in the amount of the current list price of the parts or materials required for replacement, repair, or modification of the equipment.

Freight costs shall be paid by the dealer/customer.

This warranty extends only to the original user of KIFCO equipment purchased from an authorized KIFCO dealership.

This warranty does not apply to certain component parts used on KIFCO equipment. Such component parts are warranted by the original manufacturer and KIFCO'S responsibility is limited to communicating the need for warranty service to each manufacturer. Such component parts include, but are not limited to tires and tubes, batteries, gearboxes, transmissions, pumps and sprinklers.

This warranty shall be available only if:

- A. KIFCO has received a properly executed delivery record and
- B. KIFCO is notified in writing within 30 days upon discovery of an alleged defect and
- C. KIFCO'S examination of the equipment discloses, to its satisfaction, that such alleged defect has not been caused by misuse; neglect; improper installation; improper operations; improper maintenance; repair or alteration; accident; or unusual or extraordinary use demands.

THE FOREGOING WARRANTY SUPERSEDES AND IS IN LIEU OF ALL OTHER WARRANTIES WHETHER EXPRESSED, IMPLIED OR STATUTORY, AND ALL OTHER LIABILITIES OR OBLIGATIONS ON THE PART OF KIFCO INC.

- A. KIFCO MAKES NO WARRANTY OF MERCHANTABILITY IN RESPECT TO THE EQUIPMENT.
- B. KIFCO MAKES NO WARRANTY THAT THE EQUIPMENT IS FIT FOR ANY PARTICULAR PURPOSE.

### LIMITATION OF LIABILITY

KIFCO SHALL IN NO EVENT BE LIABLE FOR ANY CONSEQUENTIAL DAMAGES (INCLUDING BUT NOT LIMITED TO, DAMAGES FOR INJURY TO THE PERSON OR PROPERTY OR LOST PROFITS) OR ANY INCIDENTAL OR SPECIAL DAMAGES AND/OR EXPENSES, OR CLAIMS FOR INDEMNIFICATION, BY REASON OF ANY DEFECT IN THE EQUIPMENT OR ITS MANUFACTURE, DESIGN OR FUNCTIONING, OR ANY INSTRUCTIONS CONCERNING THE EQUIPMENT.

No agent or representative of KIFCO or any of its dealerships has authority to waive, alter or add to the printed provisions of this warranty and limitations of liability.

**KIFCO INC.**  
700 SOUTH SCHRADER AVE  
HAVANA, ILLINOIS 62644





## Polyethylene Tube Warranty

The polyethylene tubing used on AG-RAIN WATER-REELS is warranted to the original user to be free from defects in material and workmanship according to the following terms:

1. In the event that such polyethylene tubing is discovered or should have been discovered to be defective within the warranty period specified below and it is shown to the satisfaction of KIFCO INC. that such defect was caused by faulty workmanship or materials, the tubing will be, at KIFCO's option, either repaired or replaced according to the following:

0 to 10 months---full credit.

Beginning with the 11th month through the 60th month the credit issued for either repair or replacement shall be reduced each month by 2 percent each month. No warranty shall be available after the 60th month. Satisfaction of this warranty will be limited to the repair or replacement of the polyethylene tubing. The manufacturer's obligation under this warranty shall be limited to a credit to the dealer or customer in the amount of the current list price of the repair or replacement tube. All freight, installation cost or other incurred cost associated with the repair or replacement shall be paid by the dealer/customer.

This warranty extends only to the original user of AG-RAIN equipment purchased from an authorized AG-Rain dealership.

2. The warranty period shall commence on the date of purchase by the original user and shall terminate 60 months thereafter. In the event that the tubing is replaced, the warranty period is not extended beyond the 60 months counted from the original purchase date.
3. This warranty shall be available only if:
  - A. KIFCO has received a properly executed delivery record and
  - B. KIFCO is notified in writing within 30 days upon discovery of an alleged defect and
  - C. KIFCO's examination of the equipment discloses, that such alleged defect has not been caused by misuse; neglect; improper operations; improper maintenance; repair or alteration; accident; or unusual or extraordinary use demands and
  - D. Within a reasonable time KIFCO receives a sample of the allegedly failed tube and other evidence KIFCO may specify.

THE FOREGOING WARRANTY SUPERSEDES AND IS IN LIEU OF ALL OTHER WARRANTIES WHETHER EXPRESSED, IMPLIED OR STATUTORY, AND ALL OTHER LIABILITIES OR OBLIGATIONS ON THE PART OF KIFCO INC.

- A. KIFCO MAKES NO WARRANTY OF MERCHANTABILITY IN RESPECT TO THE EQUIPMENT.
- B. KIFCO MAKES NO WARRANTY THAT THE EQUIPMENT IS FIT FOR ANY PARTICULAR PURPOSE.

KIFCO SHALL IN NO EVENT BE LIABLE FOR ANY CONSEQUENTIAL DAMAGES (INCLUDING BUT NOT LIMITED TO, DAMAGES FOR INJURY TO THE PERSON OR PROPERTY OR LOST PROFITS) OR ANY INCIDENTAL OR SPECIAL DAMAGES AND/OR EXPENSES, OR CLAIMS FOR INDEMNIFICATION, BY REASON OF ANY DEFECT IN THE EQUIPMENT OR ITS MANUFACTURE, DESIGN OR FUNCTIONING, OR ANY INSTRUCTIONS CONCERNING THE EQUIPMENT.

No agent or representative of KIFCO or any of its dealerships has authority to waive, alter or add to the printed provisions of this warranty and limitations of liability.

**KIFCO INC.**  
700 SOUTH SCHRADER AVE  
HAVANA, ILLINOIS 62644

# Notes